



FB-Ketten

Scharnierbandketten mit einfachem Scharnier für gerade Förderanlagen

"SUPER"-Hard Inox

Platten aus kaltverfestigtem und extrem widerstandsfähigem Chrom-Nickel-Edelstahl mit glänzender Oberfläche und einer Rauheit Ra kleiner/gleich 0,3 Mikron.

Bolzen aus nichtrostendem, austenitischem Stahl, 18 % Chrom und 8 % Nickel, kaltverfestigt und extrem widerstandsfähig.

"STANDARD"-Inox

Platten aus kaltverfestigtem ferritischem AISI430 Stahl mit glänzender Oberfläche und geringer Rauheit.

Bolzen aus nichtrostendem austenitischem Stahl, 18 % Chrom und 8 % Nickel, kaltverfestigt und extrem widerstandsfähig.

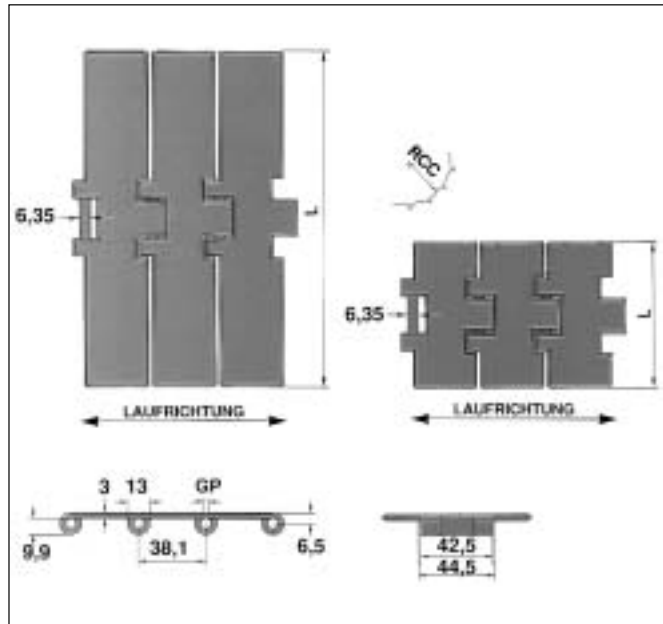

* Maße, die nur auf Bestellung hergestellt werden – Lieferbedingungen und Termine müssen vereinbart werden.

Auf Anfrage sind die genannten Ketten mit GP = 2,8 mm nun auch in der Version mit GP = 1,8 mm verfügbar. Ausgenommen davon sind die Ketten mit 54,1 mm und 127 mm Breite. Rollenverpackung 80 Platten = 10 Fuß = 3,048 m.

MODELL	L = Breite der Platten		Code	Härte HRC	GP mm	RCC mm	Gewicht/m kg/m
	mm	Zoll					
SUPER	54,1		S.7.00.013*	30	2,8	80	2,18
SUPER	57,1	2 1/4	S.7.00.015*	30	1,8	150	2,18
SUPER	63,5	2 1/2	S.7.00.020	30	2,8	80	2,2
SUPER	66,7	2 5/8	S.7.00.025	30	2,8	80	2,3
SUPER	69,9	2 3/4	S.7.00.200	30	1,8	150	2,35
SUPER	76,2	3	S.7.00.030	30	2,8	80	2,45
SUPER	82,6	3 1/4	S.7.00.040	30	2,8	80	2,6
SUPER	82,6	3 1/4	S.7.00.041	30	1,8	150	2,65
SUPER	85		S.7.00.050*	30	1,8	150	2,68
SUPER	88,9	3 1/2	S.7.00.060	30	2,8	80	2,7
SUPER	95,3	3 3/4	S.7.00.065*	30	1,8	150	2,85
SUPER	101,6	4	S.7.00.070	30	1,8	150	3
SUPER	114,3	4 1/2	S.7.00.080	30	1,8	150	3,3
SUPER	127	5	S.7.00.090*	30	2,8	80	3,5
SUPER	152,4	6	S.7.00.100	30	1,8	150	4,2
SUPER	190,5	7 1/2	S.7.00.110	30	1,8	150	5,1

* Maße, die nur auf Bestellung hergestellt werden – Lieferbedingungen und Termine müssen vereinbart werden.

Auf Anfrage sind die genannten Ketten mit GP = 2,8 mm nun auch in der Version mit GP = 1,8 mm verfügbar. Ausgenommen davon ist die Kette mit 54,1 mm Breite. Rollenverpackung 80 Platten = 10 Fuß = 3,048 m.

MODELL	L = Breite der Platten		Code	Härte HRC	GP mm	RCC mm	Gewicht/m kg/m
	mm	Zoll					
STANDARD	54,1		S.7.00.013*		2,8	80	2,18
STANDARD	57,1	2 1/4	S.7.00.015*		1,8	150	2,18
STANDARD	63,5	2 1/2	S.7.00.020*		2,8	80	2,2
STANDARD	66,7	2 5/8	S.7.00.025*		2,8	80	2,3
STANDARD	69,9	2 3/4	S.7.00.200*		1,8	150	2,35
STANDARD	76,2	3	S.7.00.030*		2,8	80	2,45
STANDARD	82,6	3 1/4	S.7.00.041		2,8	80	2,6
STANDARD	85		S.7.00.050*		1,8	150	2,68
STANDARD	88,9	3 1/2	S.7.00.060*		2,8	80	2,7
STANDARD	101,6	4	S.7.00.070		1,8	150	3
STANDARD	114,3	4 1/2	S.7.00.080		1,8	150	3,3
STANDARD	127	5	S.7.00.090		2,8	80	3,5
STANDARD	152,4	6	S.7.00.100		1,8	150	4,2
STANDARD	190,5	7 1/2	S.7.00.110		1,8	150	5,1



FB-Ketten

Scharnierbandketten mit doppeltem Scharnier für gerade Förderanlagen

"STELLA D."-Inox 18/8

Platten aus kaltverfestigtem und extrem widerstandsfähigem austenitischem Chrom-Nickel-Edelstahl AISI 304, 18 % Chrom und 8 % Nickel, mit glänzender Oberfläche und einer Rauheit RA < 0,6 Mikron.

Bolzen aus nichtrostendem austenitischem Stahl, 18 % Chrom und 8 % Nickel, kaltverfestigt und extrem widerstandsfähig.

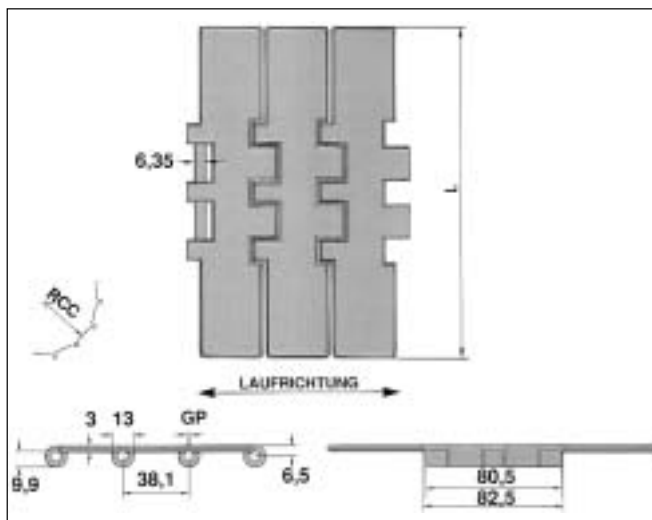

"ACCATE"-Carbon Steel

Platten und Bolzen aus karbonitriertem Kohlenstoffstahl mit einer Oberflächen- und Kernhärte von 43 HRC.

Rollenverpackung

80 Platten = 10 Fuß = 3,048 m.

MODELL	L = Breite der Platten		Code	Härte HRC	GP mm	RCC mm	Gewicht/m kg/m
	mm	Zoll					
STANDARD	190,5	7 1/2	7.04.110		1,8	150	5,8
SUPER	190,5	7 1/2	S.7.04.110		1,8	150	5,8
STELLA D	190,5	7 1/2	7.14.110		1,8	150	5,8
ACCATE	190,5	7 1/2	7.94.110		1,8	150	5,8

Andere Ausführungen und Scharnierbandketten in Kunststoff auf Anfrage.
Other executions and Flat-Top-Chains in Plastic on demand.

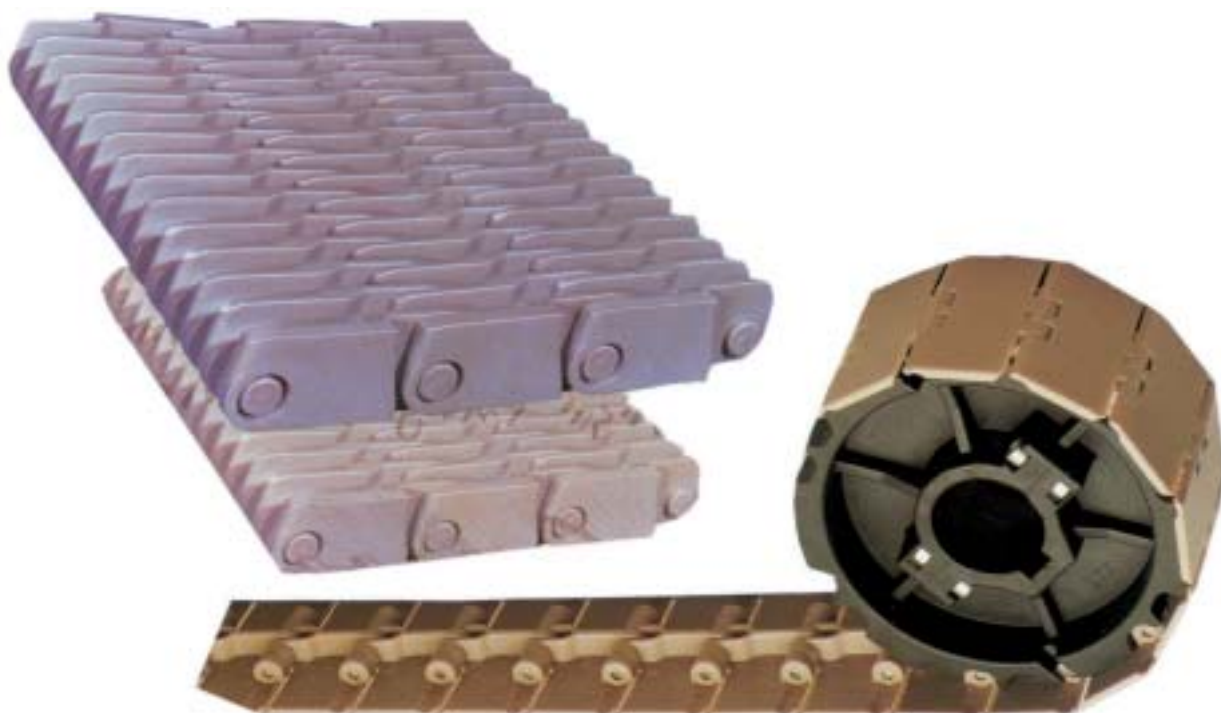

PLASTIC

- 879 LFA -

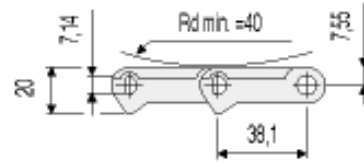
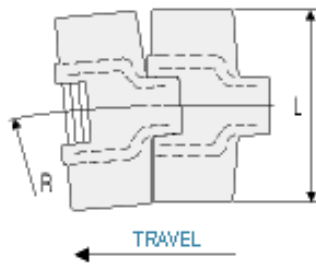
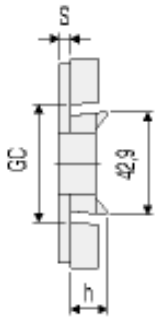
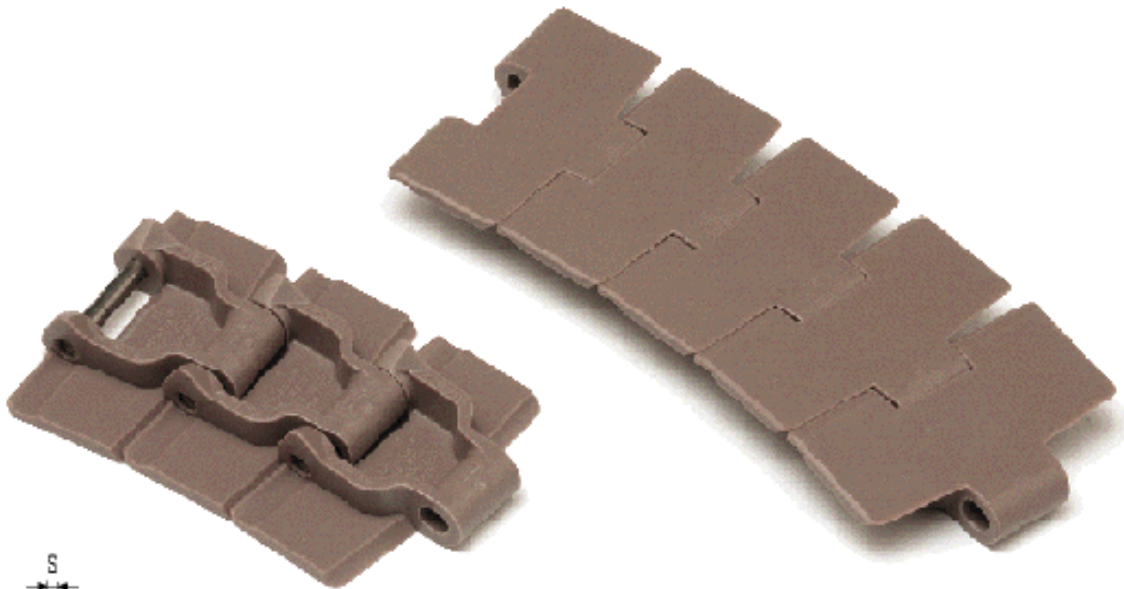

879 LFA

Low Friction Acetal Resin

- Plates in self-lubricating low friction acetal resin, light brown-coloured.
- Pins in chrome-nickel austenitic stainless steel (18% Chrome - 8% Nickel), work hardened for high resistance.

Chain ref.	Code	Material	Width L	Thickness S	Height h	Min. Radius R	GC Straight	GC Sidefl	Weight
			mm.	mm.	mm.	mm.	mm.	mm.	Kg/m
LFA 879-K 325	6.13.040	LFA Acetal Resin (Light brown)	82,5	4,8	15,2	457	44,5	41,4	0,93
LFA 879-K 450	6.13.080		114,3			610			1,10

[zurück zur Übersicht](#)

PLASTIC

- 879 BO LFA - 879 BO WR -

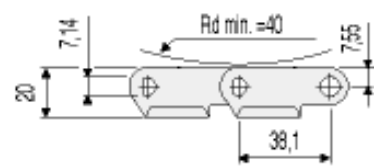
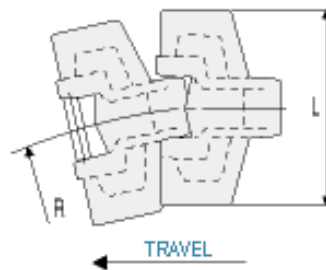
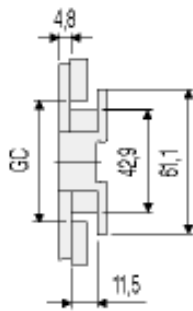
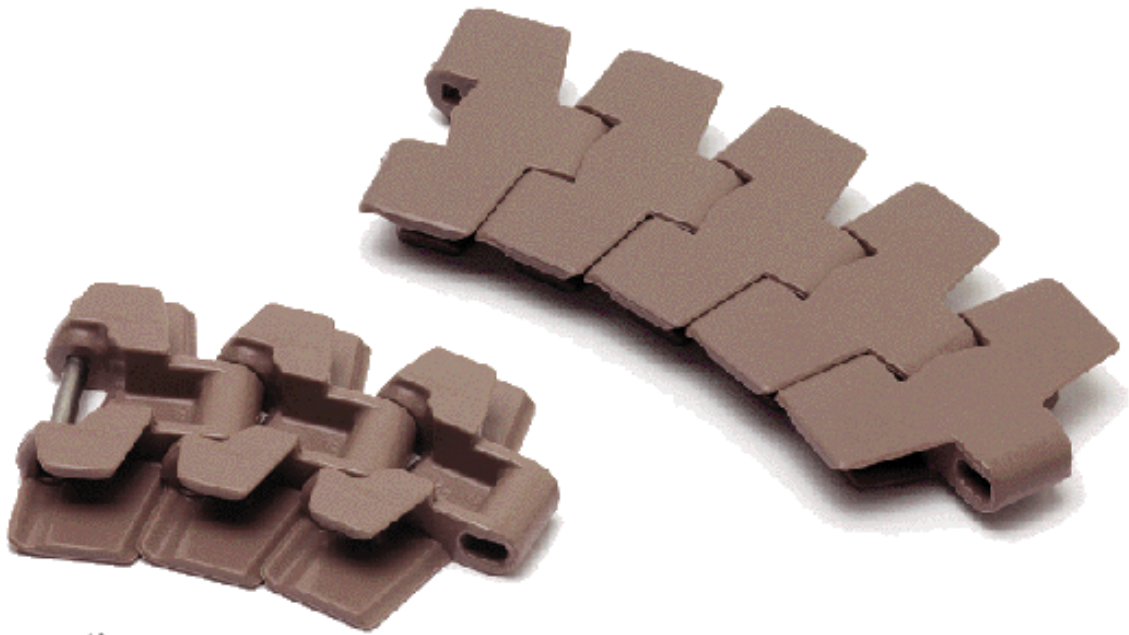

879 BO LFA

Low Friction Acetal Resin

- Plates in self-lubricating low friction acetal resin, light brown-coloured.
- Pins in chrome-nickel austenitic stainless steel (18% Chrome - 8% Nickel), work hardened for high resistance.

Chain Ref.	Code	Material	Width L	Min. Radius R	GC Straight	GC Sidefl.	Weight
			mm.	mm.	mm.	mm.	Kg/m
LFA 879 BO - K 325	6.17.040	LFA Acetal Resin (Light brown)	82,5	200	46	44,2	1,08
LFA 879 BO - K 450	6.17.080		114,3				1,23

879 BO WR

Wear Resistant Resin

- Plates in thermoplastic wear resistant resin, black-coloured.
- Pins in chrome-nickel austenitic stainless steel (18% Chrome - 8% Nickel), work hardened for high resistance.

Chain Ref.	Code	Material	Width L	Min. Radius R	GC Straight	GC Sidefl.	Weight
			mm.	mm.	mm.	mm.	Kg/m
WR 879 BO - K 325	6.57.040	WR Thermoplastic Resin (Black)	82,5	200	46	44,2	1,08
WR 879 BO - K 450	6.57.080		114,3				1,23

[zurück zur Übersicht](#)

PLASTIC

- [879 Tab LFA](#) - [879 Tab SP](#) -

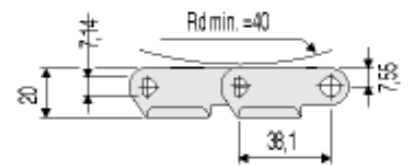
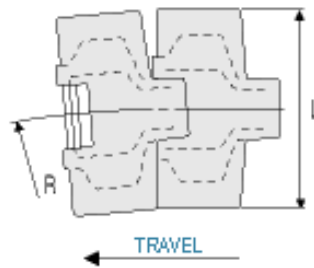
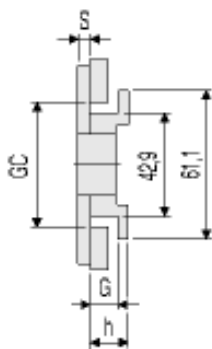
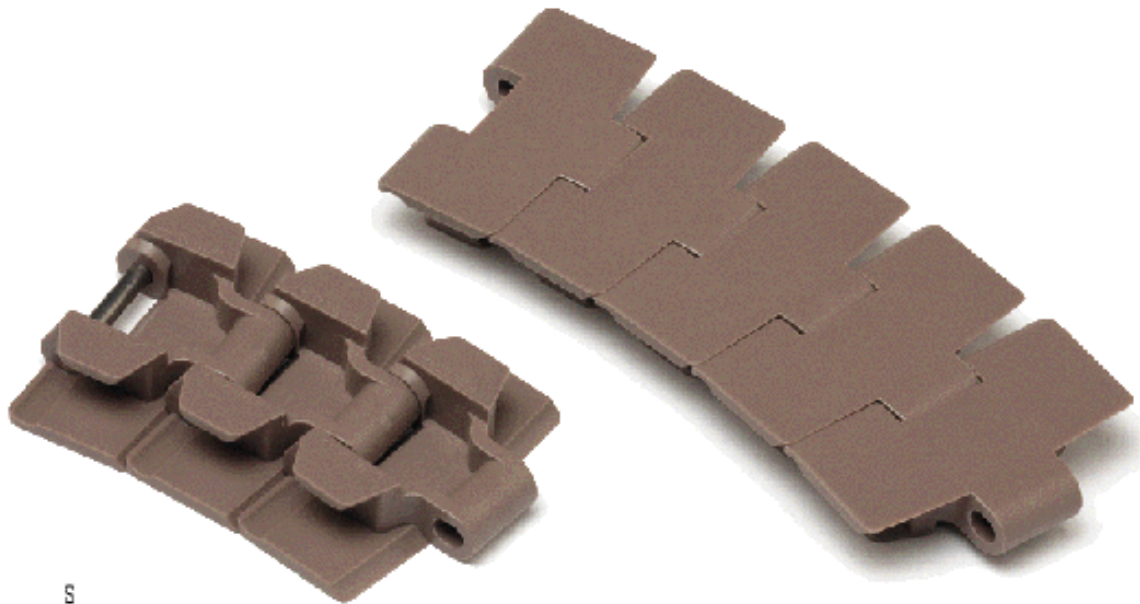

879 Tab LFA

Low Friction Acetal Resin

- Plates in self-lubricating low friction acetal resin, light brown-coloured.
- Pins in chrome-nickel austenitic stainless steel (18% Chrome - 8% Nickel), work hardened for high resistance.

Chain Ref.	Code	Material	Width L	Thickness S	G	Height h	Min. Radius R	GC Straight	GC Sidefl.	Weight
			mm.	mm.	mm.	mm.	mm.	mm.	mm.	Kg/m
LFA 879 Tab-K 325	6.13.041	LFA Acetal Resin (Light brown)	82,5	4,8	11	15,2	457	46	44,2	0,98
LFA 879 Tab-K 450	6.13.081		114,3				610			1,14

879 Tab SP

Super Performance Acetal Resin

- Plates in self-lubricating very low friction acetal resin, dark grey-coloured.
- Pins in chrome-nickel austenitic stainless steel (18% Chrome - 8% Nickel), work hardened for high resistance.

Chain Ref.	Code	Material	Width L	Thickness S	G	Height h	Min. Radius R	GC Straight	GC Sidefl.	Weight
			mm.	mm.	mm.	mm.	mm.	mm.	mm.	Kg/m
SP 879 Tab-K 325	6.23.041	SP Acetal Resin (Dark grey)	82,5	4,8	11	15,2	457	46	44,2	0,98
SP 879 Tab-K 450	6.23.081		114,3				610			1,14

[zurück zur Übersicht](#)

PLASTIC

- 880 LFA - 880 SP - 880 WR -

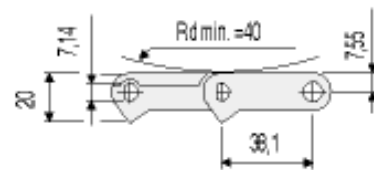
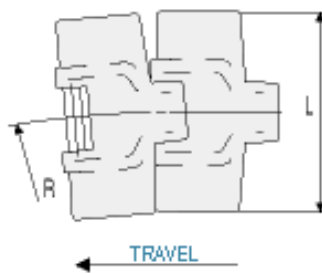
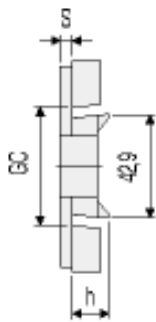
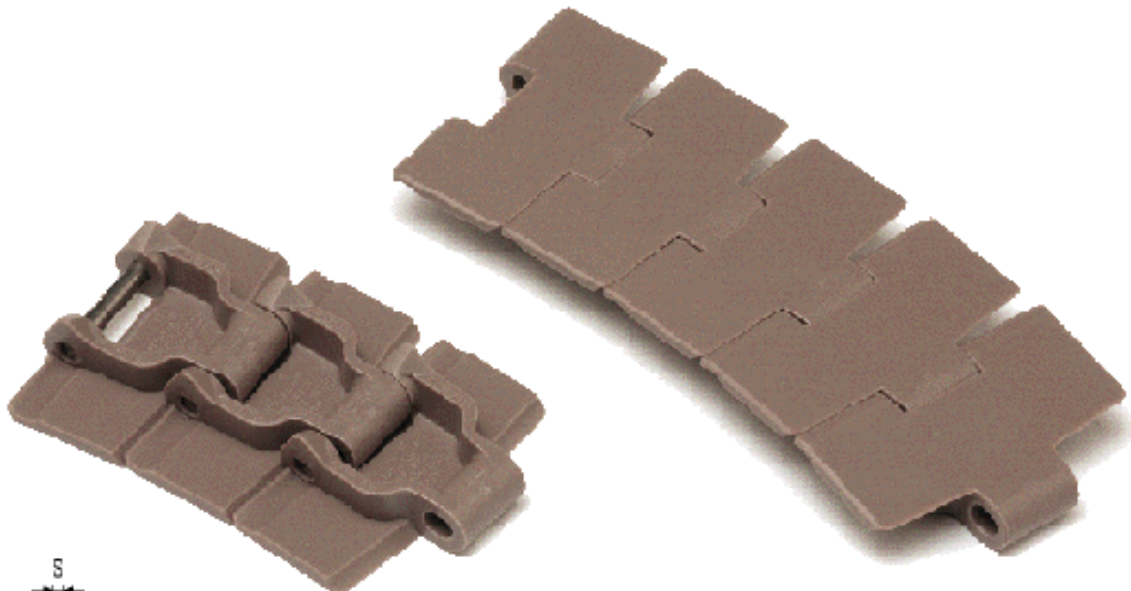

880 LFA

Low Friction Acetal Resin

- Plates in self-lubricating low friction acetal resin, light brown-coloured.
- Pins in chrome-nickel austenitic stainless steel (18% Chrome - 8% Nickel), work hardened for high resistance.

Chain Ref.	Code	Material	Width L	Thickness S	Height h	Min. Radius R	GC Straight	GC Sidefl.	Weight
			mm.	mm.	mm.	mm.	mm.	mm.	Kg/m
LFA 880-K 325	6.12.040	LFA Acetal Resin (Light brown)	82,5	4	16	457	44,5	41,4	0,89
LFA 880-K 450	6.12.080		114,3			610			1,04
LFA 880-K 750	6.12.110		190,5			610			1,40

880 SP

Super Performance Acetal Resin

- Plates in self-lubricating very low friction acetal resin, dark grey-coloured.
- Pins in chrome-nickel austenitic stainless steel (18% Chrome - 8% Nickel), work hardened for high resistance.

Chain Ref.	Code	Material	Width L	Thickness S	Height h	Min. Radius R	GC Straight	GC Sidefl.	Weight
			mm.	mm.	mm.	mm.	mm.	mm.	Kg/m
SP 880-K 325	6.22.040	SP Acetal Resin (Dark grey)	82,5	4	16	457	44,5	41,4	0,89
SP 880-K 450	6.22.080		114,3			610			1,04
SP 880-K 750	6.22.110		190,5			610			1,40

880 WR

Wear Resistant resin

- Plates in thermoplastic wear resistant resin, black-coloured.
- Pins in chrome-nickel austenitic stainless steel (18% Chrome - 8% Nickel), work hardened for high resistance.

Chain Ref.	Code	Material	Width L	Thickness S	Height h	Min. Radius R	GC Straight	GC Sidefl.	Weight
			mm.	mm.	mm.	mm.	mm.	mm.	Kg/m
WR 880-K 325	6.52.040	WR Thermoplastic Resin (Black)	82,5	4	16	457	44,5	41,4	0,89
WR 880-K 450	6.52.080		114,3			610			1,04

[zurück zur Übersicht](#)

- 880 BO LFA - 880 BO WR -

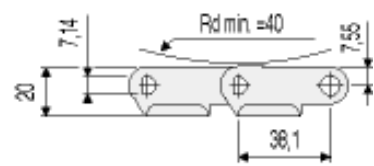
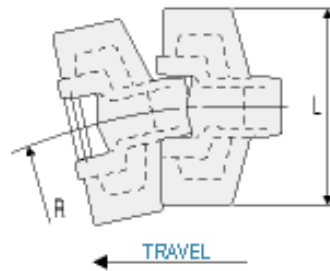
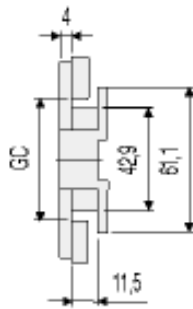
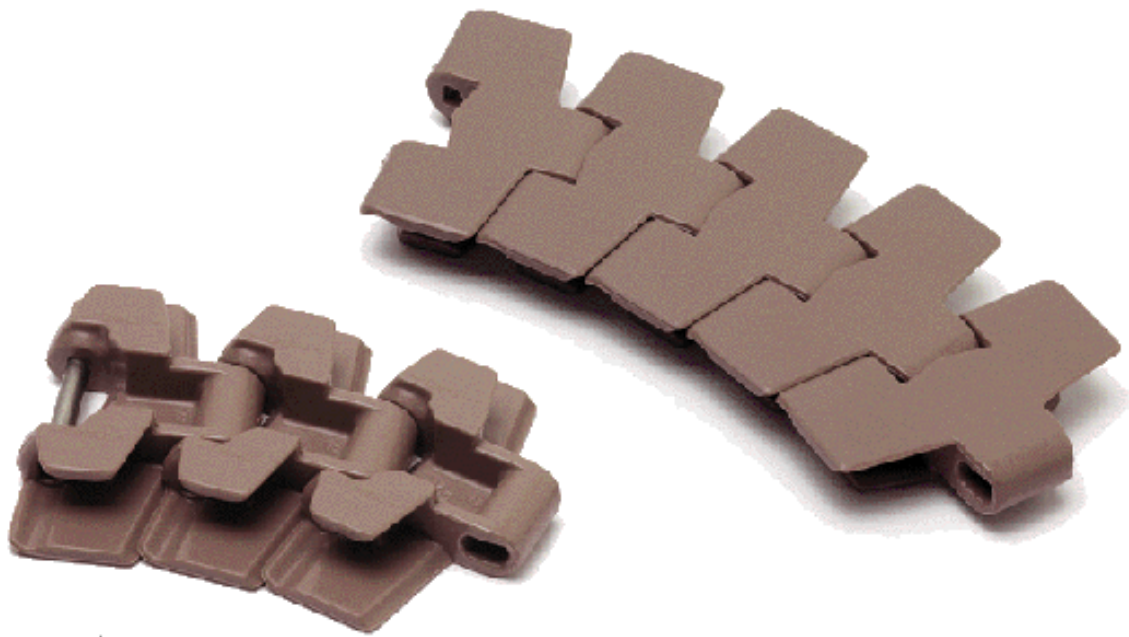

880 BO LFA

Low Friction Acetal Resin

- Plates in self-lubricating low friction acetal resin, light brown-coloured.
- Pins in chrome-nickel austenitic stainless steel (18% Chrome - 8% Nickel), work hardened for high resistance.

Chain ref.	Code	Material	Width L	Min. Radius. R	GC Straight	GC Sidefl.	Weight
			mm.	mm.	mm.	mm.	Kg/m
LFA 880 BO - K 325	6.19.040	LFA Acetal resin (Light brown)	82,5	200	46	44,2	0,96
LFA 880 BO - K 450	6.19.080		114,3				1,11

880 BO WR

Wear Resistant Resin

- Plates in thermoplastic wear resistant resin, black-coloured.
- Pins in chrome-nickel austenitic stainless steel (18% Chrome - 8% Nickel), work hardened for high resistance.

Chain ref.	Code	Material	Width L	Min. Radius. R	GC Straight	GC Sidefl.	Weight
			mm.	mm.	mm.	mm.	Kg/m
WR 880 BO - K 325	6.59.040	WR Thermoplastic Resin (Black)	82,5	200	46	44,2	0,96
WR 880 BO - K 450	6.59.080		114,3				1,11

[zurück zur Übersicht](#)

- 880 M LFA - 880 M SP -

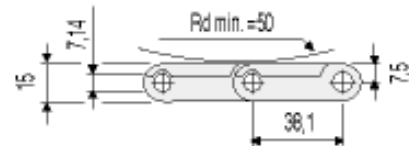
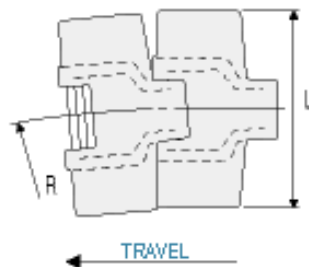
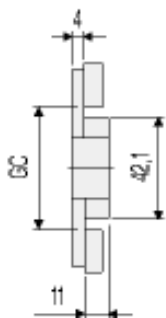
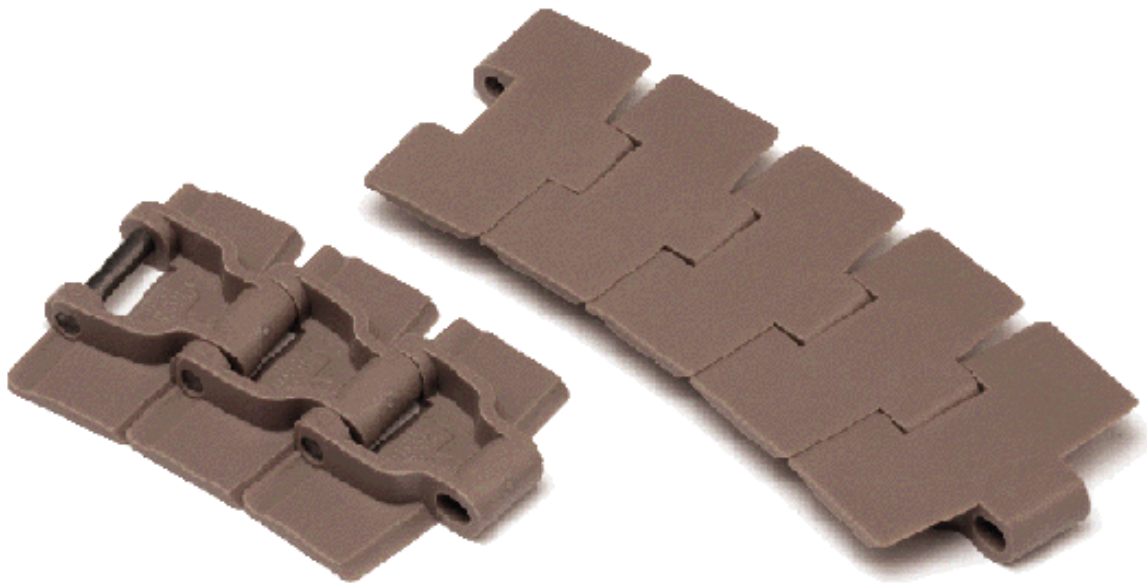

880 M LFA

Low Friction Acetal Resin

- Plates in self-lubricating low friction acetal resin, light brown-coloured.
- Pins in special stainless steel, 400 series, work hardened, magnetic, highly wear resistant.

Chain ref.	Code	Material	Width L	Min. Radius. R	GC Straight	GC Sidefl.	Weight
------------	------	----------	------------	----------------	----------------	---------------	--------

			mm.	mm.	mm.	mm.	Kg/m
LFA 880 M - K 325	6.18.040	LFA Acetal Resin (Light brown)	82,5	457	44	44	1,03
LFA 880 M - K 330	6.18.042		83,8				1,03
LFA 880 M - K 450	6.18.080		114,3				1,16

880 M SP

Super Performance Acetal Resin

- Plates in self-lubricating very low friction acetal resin, dark grey-coloured.
- Pins in special stainless steel, 400 series, work hardened, magnetic, highly wear resistant.

Chain ref.	Code	Material	Width L	Min. Radius. R	GC Straight	GC Sidefl.	Weight
			mm.	mm.	mm.	mm.	Kg/m
SP 880 M - K 325	6.28.040	SP Acetal Resin (Dark grey)	82,5	457	44	44	1,03
SP 880 M - K 450	6.28.080		114,3				1,16

[zurück zur Übersicht](#)

PLASTIC

- 880 Tab D - 880 Tab LFA - 880 Tab SP - 880 Tab AS - 880 Tab WR -
- 880 Tab Vacuum LFA -

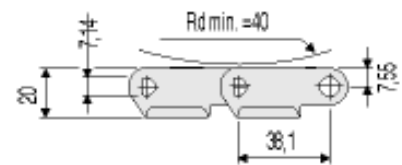
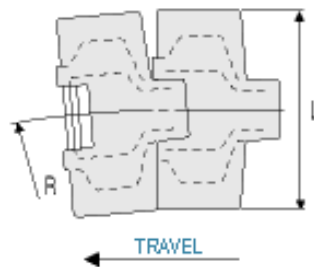
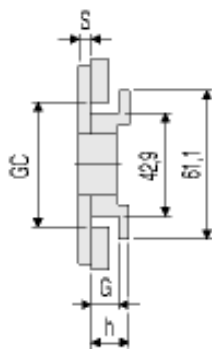
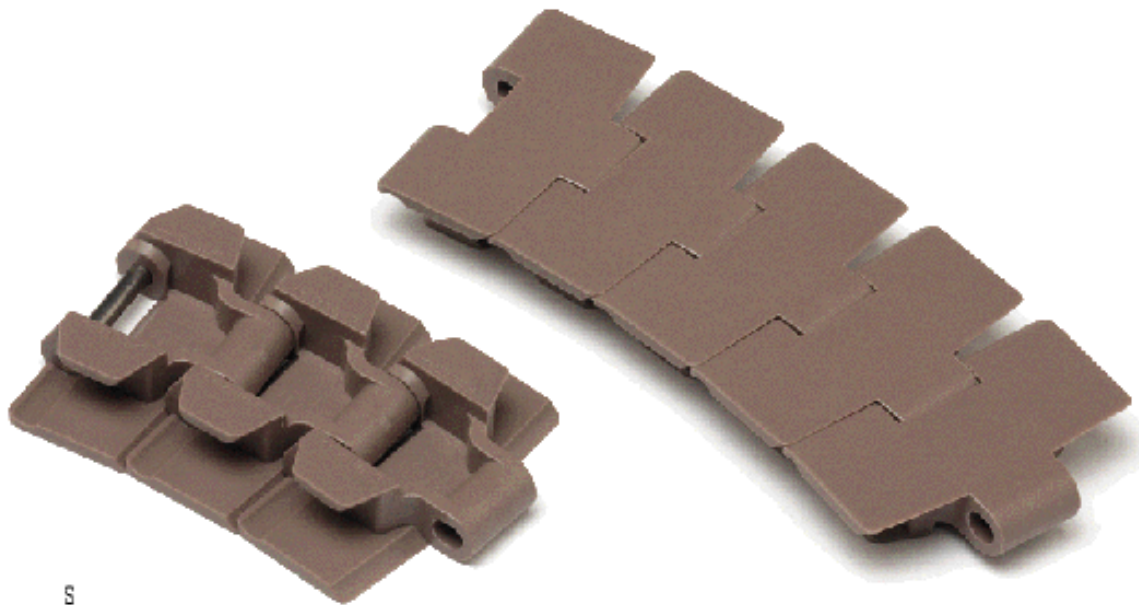

880 Tab D

Acetal Resin

- Plates in self-lubricating acetal resin, light grey-coloured.
- Pins in chrome-nickel austenitic stainless steel (18% Chrome - 8% Nickel), work hardened for high resistance.

Chain ref.	Code	Material	Width L	Thickness S	G	Height h	Min. Radius. R	GC Straight	GC Sidefl.	Weight
			mm.	mm.	mm.	mm.	mm.	mm.	mm.	Kg/m
D 880 Tab -K 325	6.02.041	D Acetal Resin (Light grey)	82,5	4	11,5	16	457	46	44,2	0,94
D 880 Tab -K 350	6.02.061		88,9				500			1,01
D 880 Tab -K 450	6.02.081		114,3				500			1,08
D 880 Tab -K 750	6.02.111		190,5				610			1,48

880 Tab LFA

Low Friction Acetal Resin

- Plates in self-lubricating low friction acetal resin, light brown-coloured.
- Pins in chrome-nickel austenitic stainless steel (18% Chrome - 8% Nickel), work hardened for high resistance.

Chain ref.	Code	Material	Width L	Thickness S	G	Height h	Min. Radius. R	GC Straight	GC Sidefl.	Weight
			mm.	mm.	mm.	mm.	mm.	mm.	mm.	Kg/m
LFA 880 Tab - K 325	6.12.041	LFA Acetal Resin (Light brown)	82,5	4	11,5	16	457	46	44,2	0,94
LFA 880 Tab - K 343	6.12.043		87,0				500			0,99
LFA 880 Tab - K 350	6.12.061		88,9				500			1,01
LFA 880 Tab - K 450	6.12.081		114,3				500			1,08
LFA 880 Tab - K 750	6.12.111		190,5				610			1,48

880 Tab SP

Super Performance Acetal Resin

- Plates in self-lubricating very low friction acetal resin, dark grey-coloured.
- Pins in chrome-nickel austenitic stainless steel (18% Chrome - 8% Nickel), work hardened for high resistance.

Chain ref.	Code	Material	Width L	Thickness S	G	Height h	Min. Radius. R	GC Straight	GC Sidefl.	Weight
			mm.	mm.	mm.	mm.	mm.	mm.	mm.	Kg/m
SP 880 Tab - K 325	6.22.041	SP Acetal Resin (Dark grey)	82,5	4	11,5	16	457	46	44,2	0,94
SP 880 Tab - K 343	6.22.043		87,0				500			0,99
SP 880 Tab - K 350	6.22.061		88,9				500			1,01
SP 880 Tab - K 450	6.22.081		114,3				500			1,08
SP 880 Tab - K 750	6.22.111		190,5				610			1,48

880 Tab AS

Antistatic Acetal Resin

- Plates in antistatic conductive acetal resin, black-coloured.
- Pins in chrome-nickel austenitic stainless steel (18% Chrome - 8% Nickel), work hardened for high resistance.

Chain ref.	Code	Material	Width L	Thickness S	G	Height h	Min. Radius. R	GC Straight	GC Sidefl.	Weight
			mm.	mm.	mm.	mm.	mm.	mm.	mm.	Kg/m
AS 880 Tab -K 325	6.32.041	AS Acetal Resin (Black)	82,5	4	11,5	16	457	46	44,2	0,94
AS 880 Tab -K 450	6.32.081		114,3				500			1,08

880 Tab WR

Wear Resistant Resin

- Plates in thermoplastic wear resistant resin, black-coloured.
- Pins in chrome-nickel austenitic stainless steel (18% Chrome - 8% Nickel), work hardened for high resistance.

Chain ref.	Code	Material	Width L	Thickness S	G	Height h	Min. Radius. R	GC Straight	GC Sidefl.	Weight
			mm.	mm.	mm.	mm.	mm.	mm.	mm.	Kg/m
WR 880 Tab-K 325	6.52.041	WR Thermoplastic Resin (Black)	82,5	4	11,5	16	457	46	44,2	0,94
WR 880 Tab-K 450	6.52.081		114,3				500			

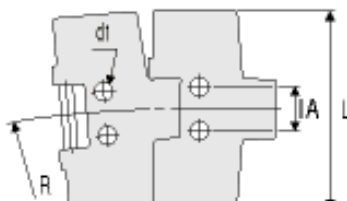
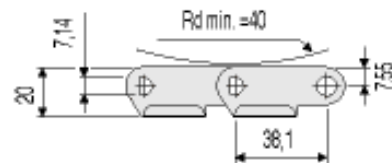
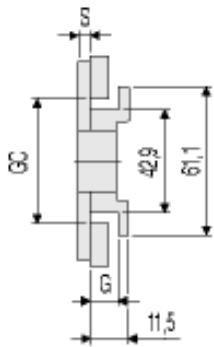
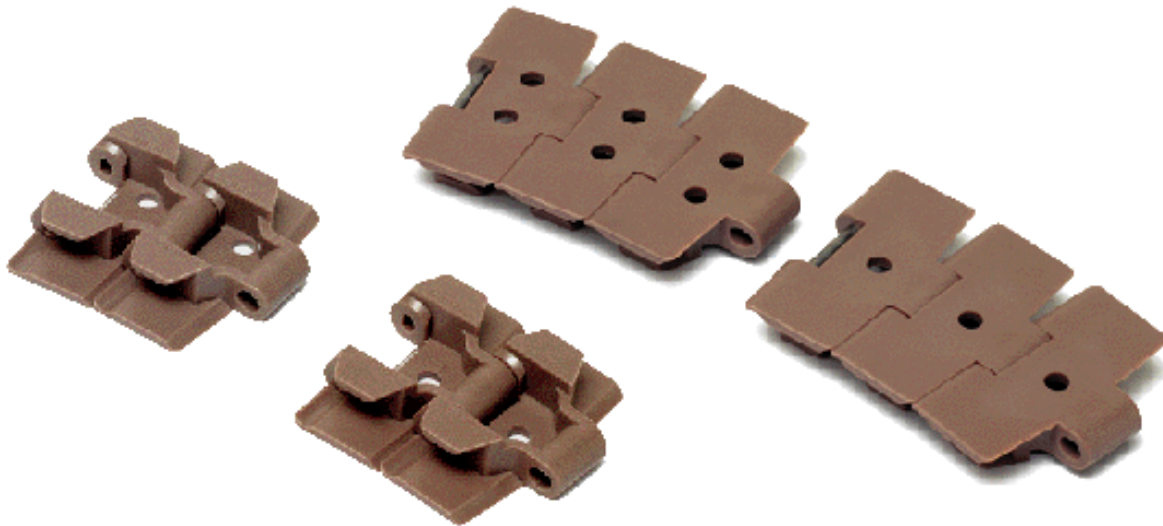



880 Tab Vacuum LFA

Low Friction Acetal Resin

- Plates in self-lubricating low friction acetal resin, light brown-coloured.
- Pins in chrome-nickel austenitic stainless steel (18% Chrome - 8% Nickel), work hardened for high resistance.

Chain ref.	Code	Material	Width L	ØBore d1	IA*	Min Radius	GC Straight	GC Sidefl.	Weight
			mm.	mm.	mm.	mm.	mm.	mm.	Kg/m
B1 One bore									
LFA 880 Tab - K 325 B 1...	6.12.041.1...	LFA Acetal Resin (light brown)	82,5	5 / 6 / 6,5	-	457	46	44,2	0,94
				8 / 9,5 / 10	-				
B2 Two bores									
LFA 880 Tab -K 325 B 2...	6.12.041.2a		82,5	6	24	457	46	44,2	0,94
	6.12.041.2b			8	20				
LFA 880 Tab - K 450 B 2...	6.12.081.2a		114,3	6	24	610	46	44,2	1,08

*IA = Distance between centers

[zurück zur Übersicht](#)

PLASTIC

- 882 LFA -

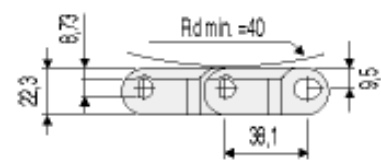
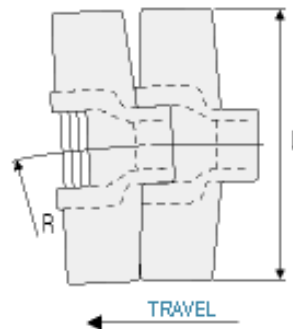
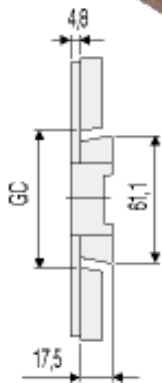

882 LFA

Low Friction Acetal Resin

- Plates in self-lubricating low friction acetal resin, light brown-coloured.
- Pins in chrome-nickel austenitic stainless steel (18% Chrome - 8% Nickel), work hardened for high resistance.

Chain ref.	Code	Material	Width L	Min Radius	GC Straight	GC Sidefl.	Weight
			mm.	mm.	mm.	mm.	Kg/m
LFA 882 - K 450	6.15.080	LFA Acetal Resin (Light Brown)	114,3	610	61,9	58	1,94
LFA 882 - K 750	6.15.110		190,5				2,38
LFA 882 - K 1000	6.15.120		254,0				2,83
LFA 882 - K 1200	6.15.130		304,8				2,75

[zurück zur Übersicht](#)

PLASTIC

- [882 Tab LFA](#) - [882 Tab SP](#) -

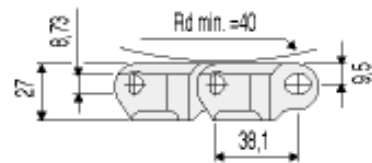
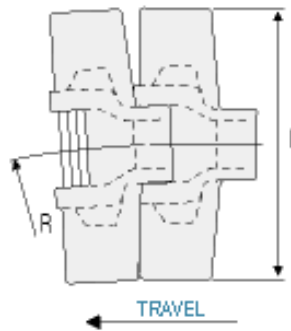
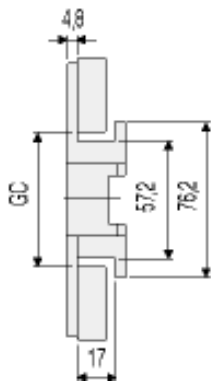
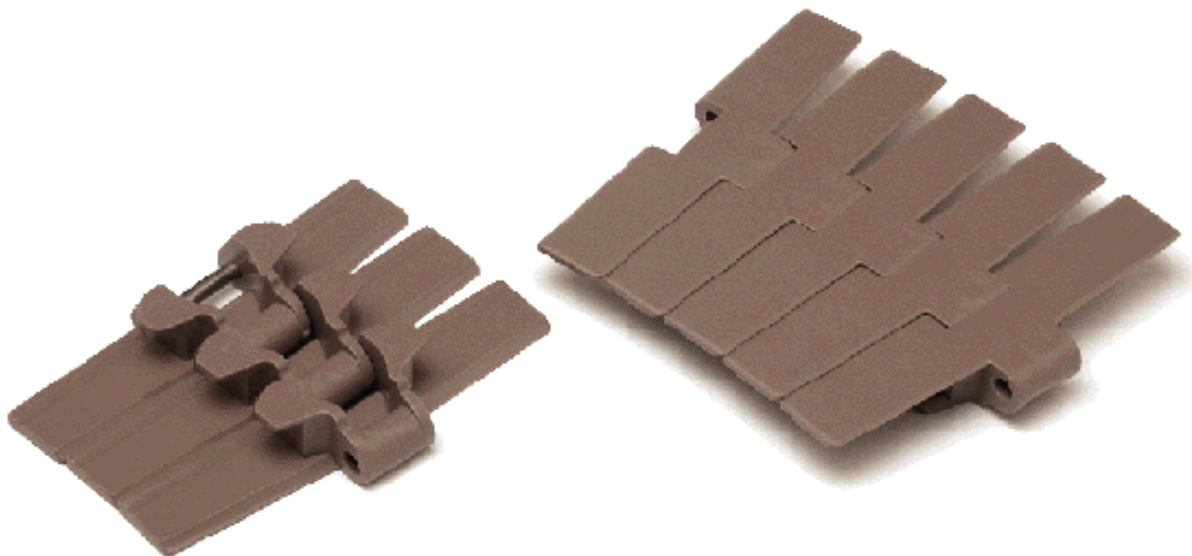

882 Tab LFA

Low Friction Acetal Resin

- Plates in self-lubricating low friction acetal resin, light brown-coloured.
- Pins in chrome-nickel austenitic stainless steel (18% Chrome - 8% Nickel), work hardened for high resistance.

Chain ref.	Code	Material	Width L	Min Radius	GC Straight	GC Sidefl.	Weight
			mm.	mm.	mm.	mm.	Kg/m
LFA 882 Tab - K 450	6.15.081	LFA Acetal Resin (Light brown)	114,3	610	60	58	1,98
LFA 882 Tab - K 750	6.15.111		190,5				2,43
LFA 882 Tab - K 1000	6.15.121		254,0				2,87
LFA 882 Tab - K 1200	6.15.131		304,8				3,41

882 Tab SP

Super Performance Acetal Resin

- Plates in self-lubricating very low friction acetal resin, dark grey-coloured.
- Pins in chrome-nickel austenitic stainless steel (18% Chrome - 8% Nickel), work hardened for high resistance.

Chain ref.	Code	Material	Width L	Min Radius	GC Straight	GC Sidefl.	Weight
			mm.	mm.	mm.	mm.	Kg/m
SP 882 Tab - K 450	6.25.081	SP Acetal Resin (Dark grey)	114,3	610	60	58	1,98
SP 882 Tab - K 750	6.25.111		190,5				2,43
SP 882 Tab - K 1000	6.25.121		254,0				2,87
SP 882 Tab - K 1200	6.25.131		304,8				3,41

[zurück zur Übersicht](#)

PLASTIC

- 820 D - 820 LFA - 820 SP - 820 AS - 820 PPB - 820 WR
- 820 Vacuum LFA -

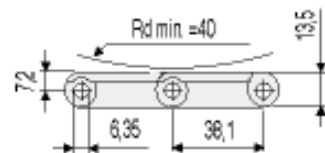
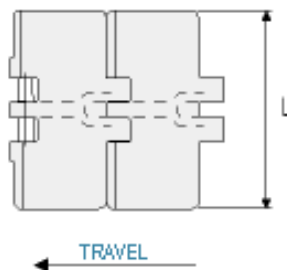
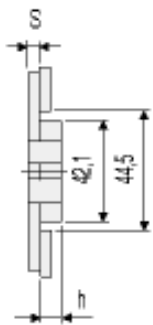
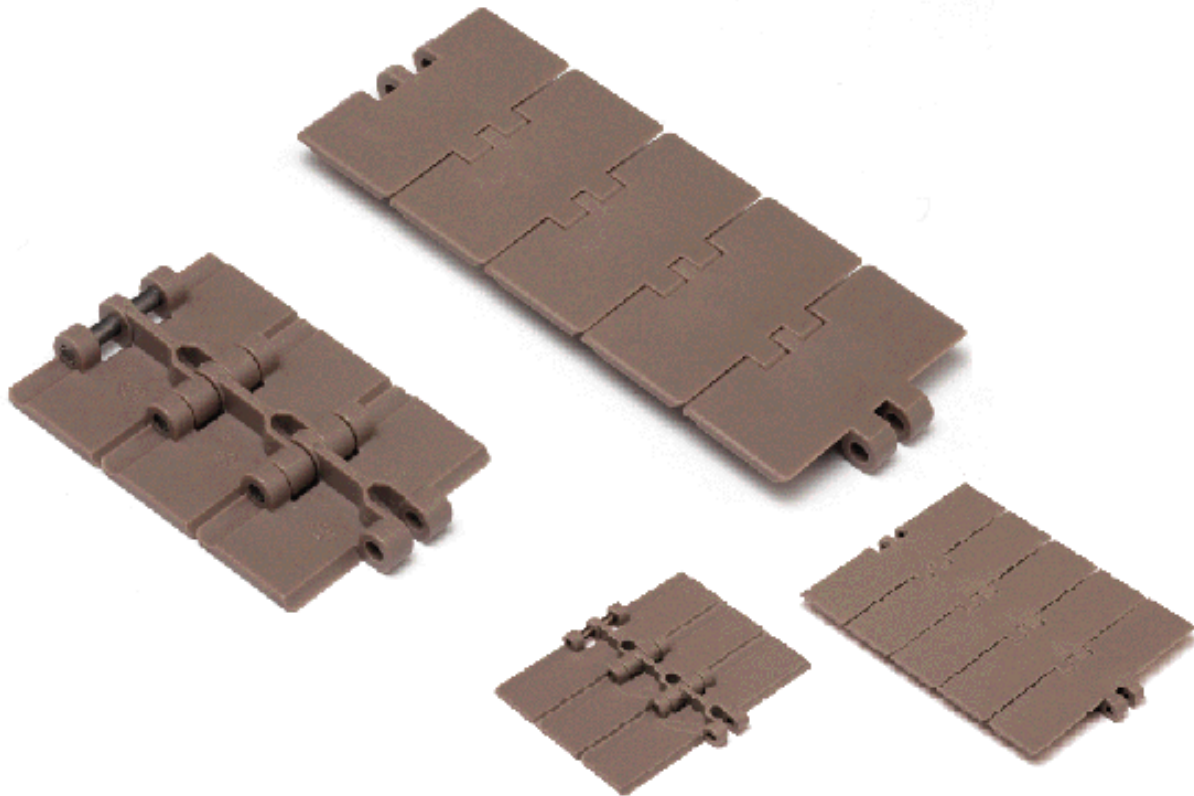

820 D

Acetal Resin

- Plates in self-lubricating acetal resin, light grey-coloured.
- Pins in chrome-nickel austenitic stainless steel (18% Chrome - 8% Nickel), work hardened for high resistance.

Chain Ref.	Code	Material	Width L	Thickness S	Height h	Weight
			mm.	mm.	mm.	Kg/m
D 820 - K 250	6.00.020	D Acetal resin (Light grey)	63,5	4	9,5	0,73
D 820 - K 325	6.00.040		82,5			0,83
D 820 - K 343	6.00.043		87,0			0,85
D 820 - K 350	6.00.060		88,9			0,87
D 820 - K 400	6.00.070		101,6			0,95
D 820 - K 450	6.00.080		114,3			1,03
D 820 - K 600	6.00.100		152,4			1,25
D 820 - K 750	6.00.110		190,5			1,47

820 LFA

Low Friction Acetal Resin

- Plates in self-lubricating low friction acetal resin, light brown-coloured.
- Pins in chrome-nickel austenitic stainless steel (18% Chrome - 8% Nickel), work hardened for high resistance.

Chain Ref.	Code	Material	Width L	Thickness S	Height h	Weight
			mm.	mm.	mm.	Kg/m
LFA 820 - K 250	6.10.020	LFA Acetal resin (Light brown)	63,5	4	9,5	0,73
LFA 820 - K 325	6.10.040		82,5			0,83
LFA 820 - K 330	6.10.042		83,8			0,83
LFA 820 - K 343	6.10.043		87,0			0,85
LFA 820 - K 350	6.10.060		88,9			0,87
LFA 820 - K 400	6.10.070		101,6			0,95
LFA 820 - K 450	6.10.080		114,3			1,03
LFA 820 - K 600	6.10.100		152,4			1,25
LFA 820 - K 750	6.10.110		190,5			1,47

820 SP

Super Performance Acetal Resin

- Plates in self-lubricating very low friction acetal resin, dark grey-coloured.
- Pins in chrome-nickel austenitic stainless steel (18% Chrome - 8% Nickel), work hardened for high resistance.

Chain Ref.	Code	Material	Width L	Thickness S	Height h	Weight
			mm.	mm.	mm.	Kg/m
SP 820 - K 325	6.20.040	SP Acetal Resin (Dark grey)	82,5	4	9,5	0,83
SP 820 - K 343	6.20.043		87,0			0,85
SP 820 - K 350	6.20.060		88,9			0,87
SP 820 - K 400	6.20.070		101,6			0,95
SP 820 - K 450	6.20.080		114,3			1,03
SP 820 - K 600	6.20.100		152,4			1,25
SP 820 - K 750	6.20.110		190,5			1,47

820 AS

Antistatic Acetal Resin

- Plates in antistatic conductive acetal resin, black-coloured.
- Pins in chrome-nickel austenitic stainless steel (18% Chrome -8% Nickel), work hardened for high resistance.

Chain Ref.	Code	Material	Width L	Thickness S	Height h	Weight
			mm.	mm.	mm.	Kg/m
AS 820 - K 325	6.30.040	AS Acetal Resin (Black)	82,5	4	9,5	0,83
AS 820 - K 350	6.30.060		88,9			0,87
AS 820 - K 400	6.30.070		101,6			0,95
AS 820 - K 450	6.30.080		114,3			1,03
AS 820 - K 600	6.30.100		152,4			1,25
AS 820 - K 750	6.30.110		190,5			1,47

820 PPB

Chemical Resistant Reinforced Polypropylene

- Plates in chemical resistant reinforced polypropylene, white-coloured.
- Pins in chrome-nickel austenitic stainless steel (18% Chrome -8% Nickel), work hardened for high resistance.

Chain Ref.	Code	Material	Width L	Thickness S	Height h	Weight
			mm.	mm.	mm.	Kg/m
PPB 820 - K 325	6.40.040	PPB Reinforced polypropylene (White)	82,5	4	9,5	0,70
PPB 820 - K 350	6.40.060		88,9			0,74
PPB 820 - K 400	6.40.070		101,6			0,82
PPB 820 - K 450	6.40.080		114,3			0,90
PPB 820 - K 600	6.40.100		152,4			1,05
PPB 820 - K 750	6.40.110		190,5			1,20

820 WR

Wear Resistant Resin

- Plates in thermoplastic wear resistant resin, black-coloured.
- Pins in chrome-nickel austenitic stainless steel (18% Chrome - 8% Nickel), work hardened for high resistance.

Chain Ref.	Code	Material	Width L	Thickness S	Height h	Weight
			mm.	mm.	mm.	Kg/m
WR 820 - K 325	6.50.040	WR Thermoplastic resin (Black)	82,5	4	9,5	0,83
WR 820 - K 400	6.50.070		101,6			0,95
WR 820 - K 450	6.50.080		114,3			1,03
WR 820 - K 600	6.50.100		152,4			1,05
WR 820 - K 750	6.50.110		190,5			1,47

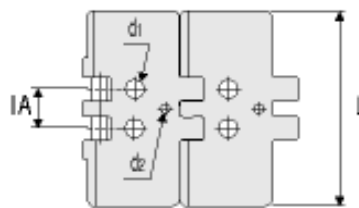
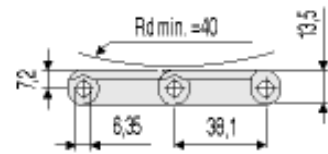
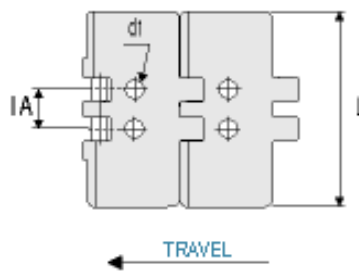
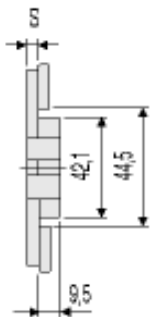
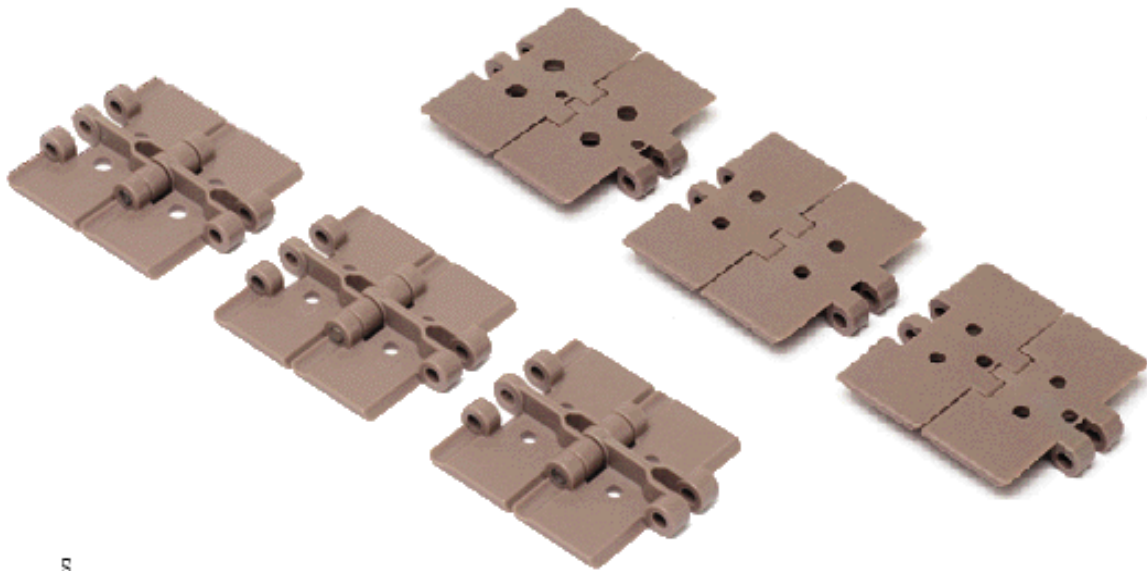

820 Vacuum LFA

Low Friction Acetal Resin

- Plates in self-lubricating low friction acetal resin, light brown-coloured.
- Pins in chrome-nickel austenitic stainless steel (18% Chrome - 8% Nickel), work hardened for high resistance.

Chain Ref.	Code	Material	Width L	ØBore d1	ØBore d2	IA*	Weight
			mm.	mm.	mm.	mm.	Kg/m
B2 Two bores							
LFA 820 - K 325 B 2	6.10.040.2	LFA Acetal Resin (Light brown)	82,5	6,5	-	19	0,83
LFA 820 - K 350 B 2	6.10.060.2		88,9	4,0	-	45	0,87
LFA 820 - K 450 B 2 H30	6.10.080.2a		114,3	8,0	-	30	1,03
LFA 820 - K 450 B 2 H50	6.10.080.2b		114,3	8,0	-	50	1,03
B3 Three bores							
LFA 820 - K 325 B 3	6.10.040.3		82,5	7,9	4,4	20	0,83

*IA = Distance between centers

PLASTIC

- 821 LFA - 821 SP -

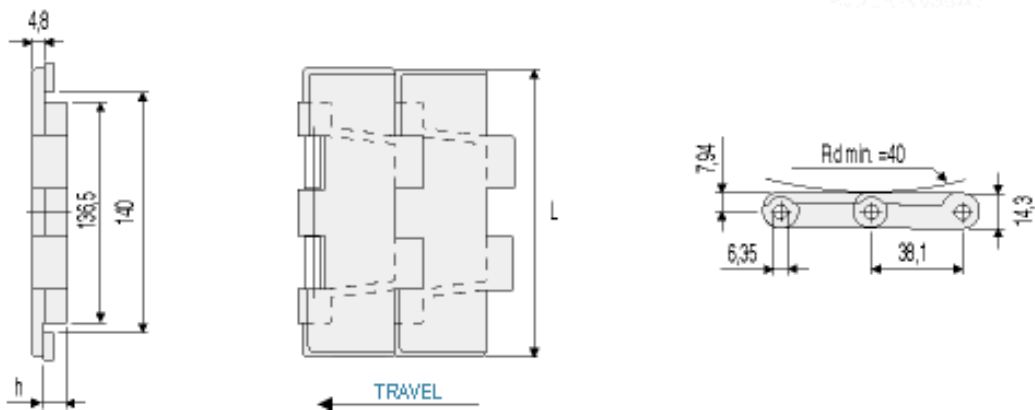
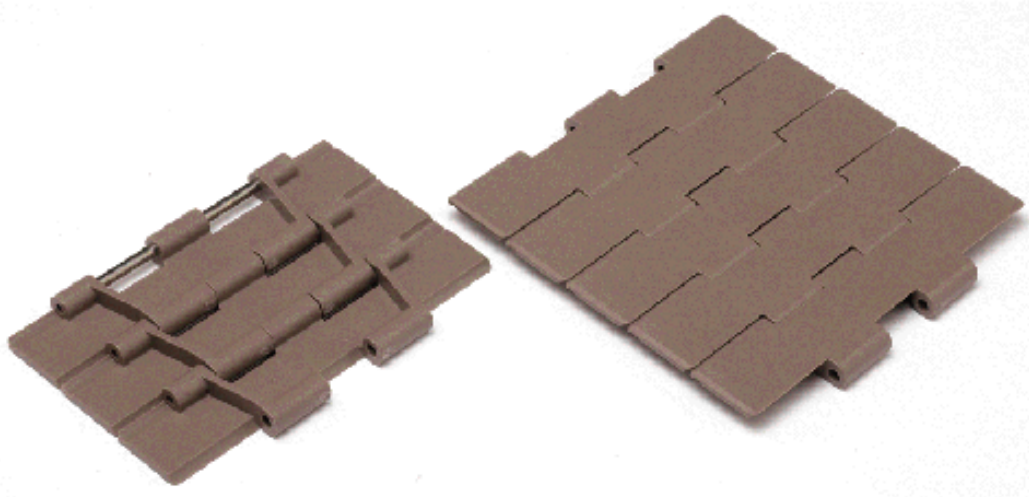

821 LFA

Low Friction Acetal Resin

- Plates in self-lubricating low friction acetal resin, light brown-coloured.
- Pins in chrome-nickel austenitic stainless steel (18% Chrome - 8% Nickel), work hardened for high resistance.

Chain Ref.	Code	Material	Width L	Weight
			mm.	Kg/m
LFA 821 - K 750	6.14.110	LFA Acetal resin (Light brown)	190,5	2,50
LFA 821 - K 1000	6.14.120		254,0	2,95
LFA 821 - K 1200	6.14.130		304,8	3,25

821 SP

Super Performance Acetal Resin

- Plates in self-lubricating very low friction acetal resin, dark grey-coloured.
- Pins in chrome-nickel austenitic stainless steel (18% Chrome - 8% Nickel), work hardened for high resistance.

Chain Ref.	Code	Material	Width L	Weight
			mm.	Kg/m
SP 821 - K 750	6.24.110	SP Acetal Resin (Dark grey)	190,5	2,50
SP 821 - K 1000	6.24.120		254,0	2,95
SP 821 - K 1200	6.24.130		304,8	3,25

[zurück zur Übersicht](#)

PLASTIC

- 831 LFA - 831 SP -

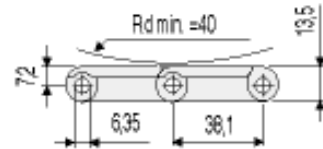
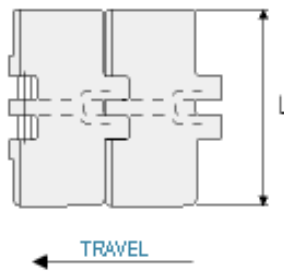
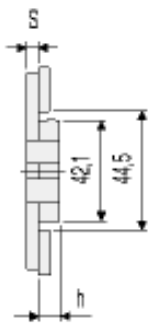
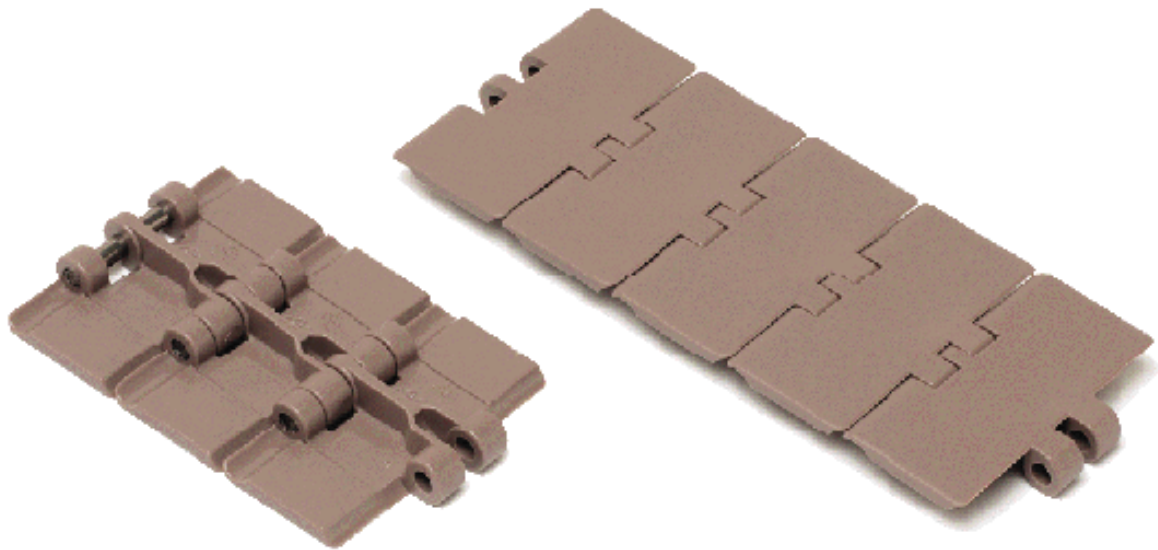

831 LFA

Low Friction Acetal Resin

- Plates in self-lubricating low friction acetal resin, light brown-coloured.
- Pins in chrome-nickel austenitic stainless steel (18% Chrome - 8% Nickel), work hardened for high resistance.

Chain Ref.	Code	Material	Width L	Thickness S	Height h	Weight
			mm.	mm.	mm.	Kg/m
LFA 831 - K 325	6.11.040	LFA Acetal Resin (Light brown)	82,5	4,8	8,7	1,00
LFA 831 - K 400	6.11.070		101,6			1,15
LFA 831 - K 450	6.11.080		114,3			1,24
LFA 831 - K 600	6.11.100		152,4			1,51
LFA 831 - K 750	6.11.110		190,5			1,76

831 SP

Super Performance Acetal Resin

- Plates in self-lubricating very low friction acetal resin, dark grey-coloured.
- Pins in chrome-nickel austenitic stainless steel (18% Chrome - 8% Nickel), work hardened for high resistance.

Chain Ref.	Code	Material	Width L	Thickness S	Height h	Weight
			mm.	mm.	mm.	Kg/m
SP 831 - K 325	6.21.040	SP Acetal Resin (Dark grey)	82,5	4,8	8,7	1,00
SP 831 - K 400	6.21.070		101,6			1,15
SP 831 - K 450	6.21.080		114,3			1,24
SP 831 - K 600	6.21.100		152,4			1,51
SP 831 - K 750	6.21.110		190,5			1,76

[zurück zur Übersicht](#)

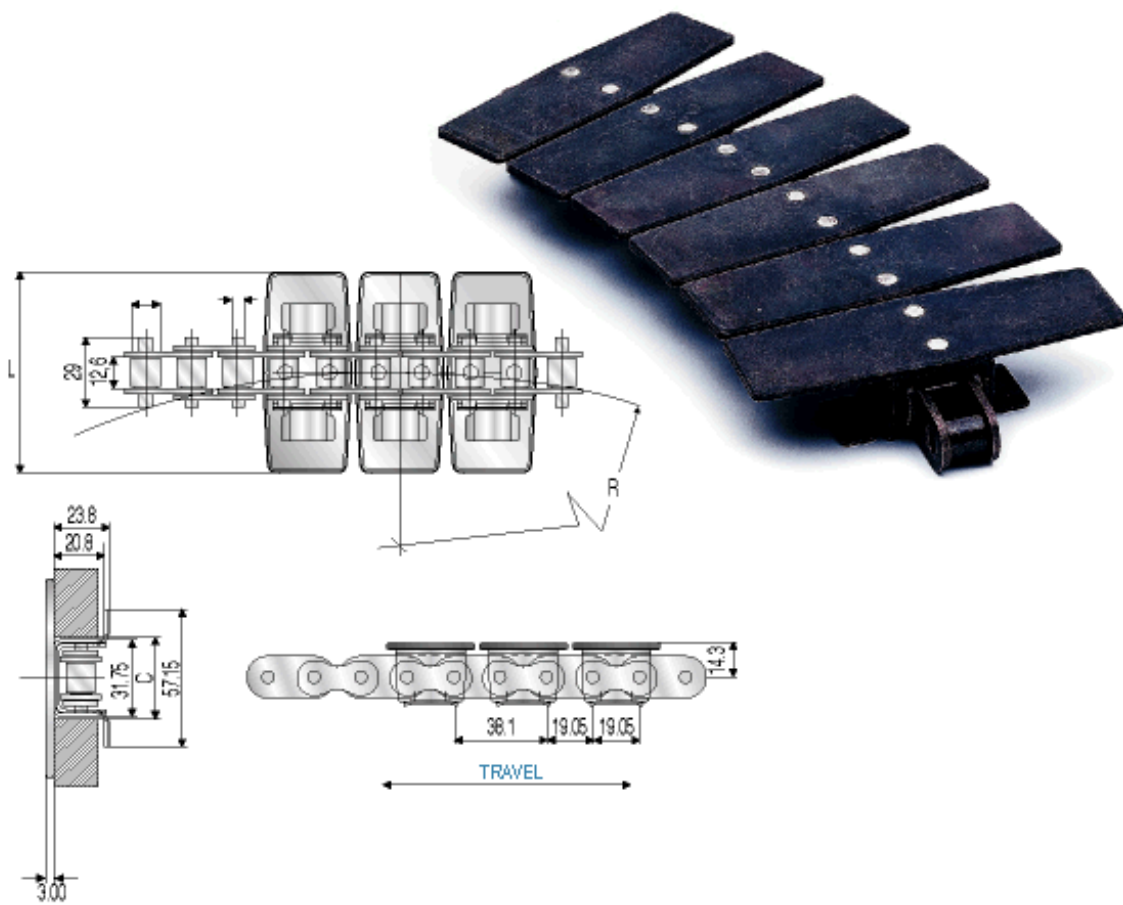

1874

- This high speed, high capacity series offers better efficiency and reliability in applications where high temperatures or abrasive materials are involved.
- Sideflexing: steel and stainless steel top plates, 19,05 mm - 3/4" pitch.

Code	Chain ref.	Ultimate strength	Base chain material	Top plate material	L= Slat width	Straight C	Curve C	R= Minimum sideflexing radius	Weight per metre
		N			mm	mm	mm	mm	Kg/m
1874.CC.041	1874 K325	27000	Steel	Steel	82,6	34,1	34,6	356	4,20
1874.CC.081	1874 K450				114,3			356	4,80
1874.CC.101	1874 K600				152,4			457	5,70
1874.CC.111	1874 K750				190,5			610	6,40
1874.CS.041	1874 A K325	27000	Steel	Stainless Steel	82,6	34,1	34,6	356	4,20
1874.CS.081	1874 A K450				114,3			356	4,80
1874.CS.101	1874 A K600				152,4			457	5,70
1874.CS.111	1874 A K750				190,5			610	6,40
1874.SS.041	1874 SS K325	21000	Stainless Steel	Stainless Steel	82,6	34,1	34,6	356	4,20
1874.SS.081	1874 SS K450				114,3			356	4,80
1874.SS.101	1874 SS K600				152,4			457	5,70
1874.SS.111	1874 SS K750				190,5			610	6,40

[zurück zur Übersicht](#)

- Super - Super-G -

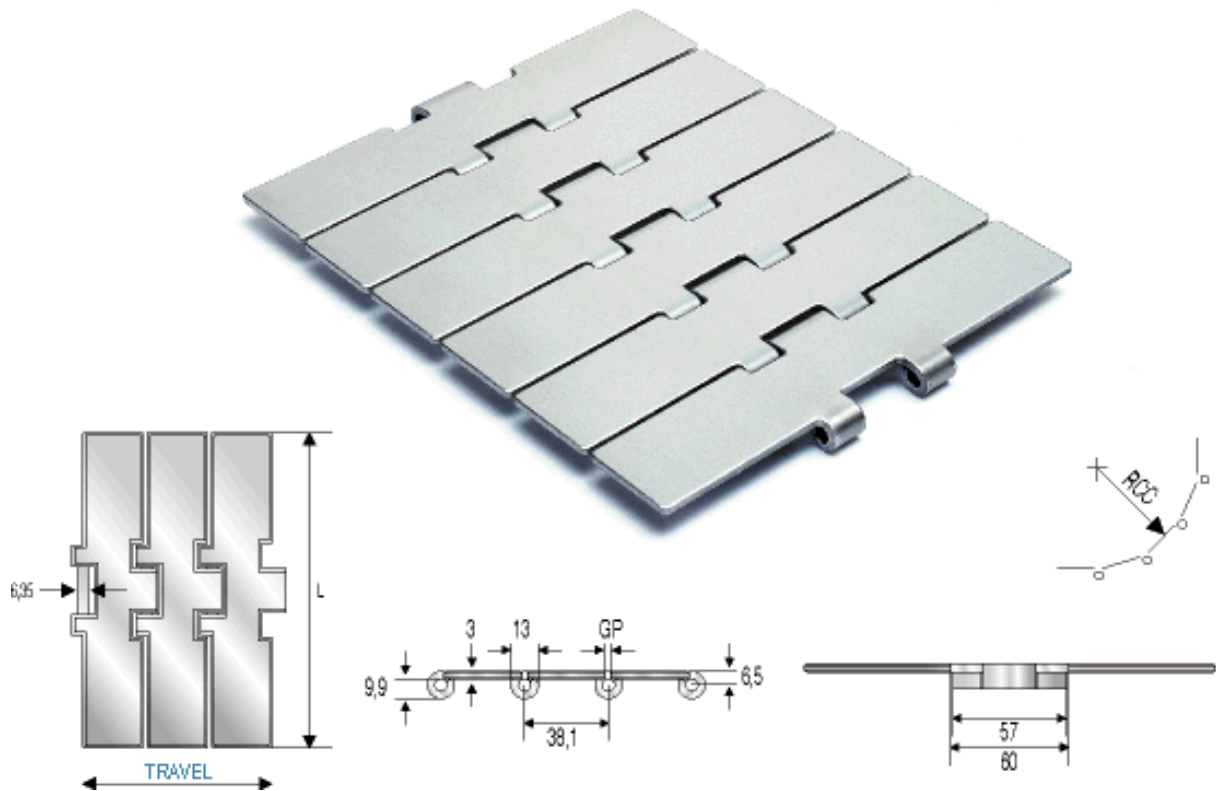

Super

Hard Inox

- Special, chrome-nickel, stainless steel, slats, work hardened for high resistance, with shiny surface having a roughness of $Ra < 0.3$ microns.
- Chrome-nickel, austenitic stainless steel pins (18% Chrome - 8% Nickel), work hardened for high resistance.

Model	L=Slat width		Code	Chain ref.	Hardness	GP	RCC	Weight per metre
	mm	"						
Super	190,5	7 1/2	S.7.00.175	SSH 8127 K750	30	1,6	150	5,10

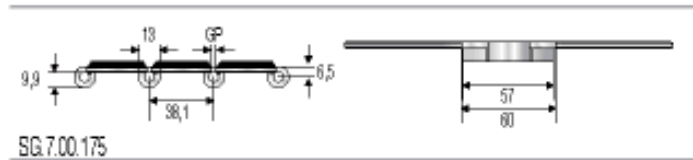
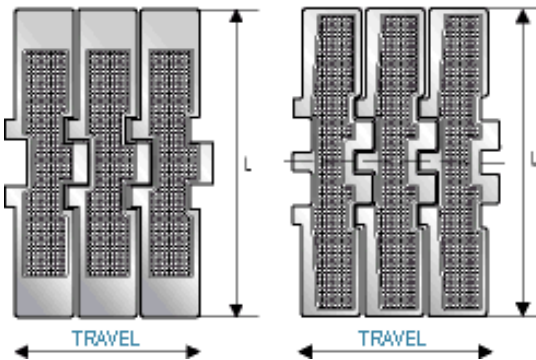
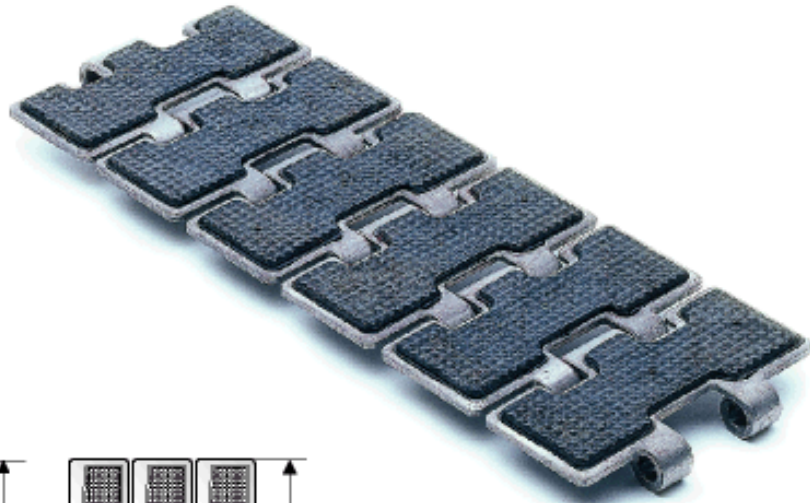

Super-G

Hard Inox

- Special, chrome-nickel, stainless steel slats, work hardened for high resistance, with a rubber insert.
- Chrome-nickel, austenitic stainless steel pins and guide shoes (18% Chrome - 8% Nickel), work hardened for high resistance.

Model	L=Slat width		Code	Chain ref.	Hardness	GP	RCC	Weight per metre
	mm	"						
Super-G	190,5	7 1/2	SG.7.00.175	SSH 8127 G K750	30	1,6	150	5,35

- [Flex RXMC](#) - [Flex RXMS](#) - [Flex RXM](#) - [Flex RXM 316](#) - [Flex RXMA](#) -
 - [Flex FMS2](#) - [Flex FM2](#) - [New Flex Mag](#) - [New Flex Mag-D](#) -
 - [Flex RXMS-G](#) / [New Flex-G Mag](#) -

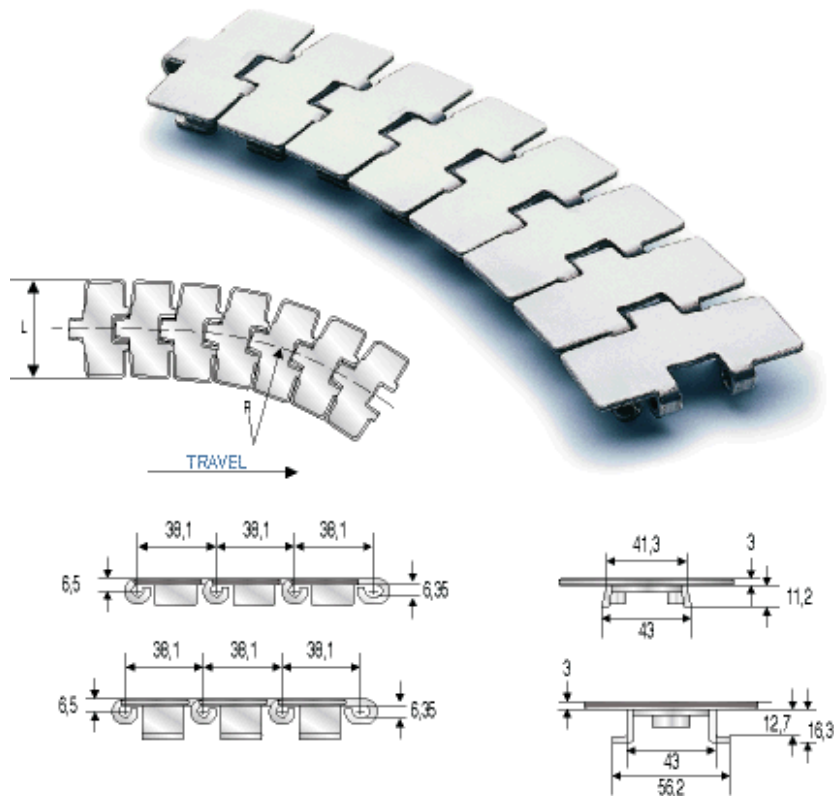

Flex RXMC

Inox

- Ferritic, AISI 430 stainless steel slats, work hardened, with shiny surface having low roughness.
- Chrome-nickel, austenitic stainless steel pins and guide shoes (18% Chrome - 8% Nickel), work hardened for high resistance.

Model	L=Slat width		Code	Chain ref.	R=Minimum sideflexing radius	Weight per metre
	mm	"			mm	Kg/m
Flex RXMC Tab	82,6	3 1/4	8.23.041	SS 881 T K325	457	3,10

Flex RXMS

Hard Inox

- Special, chrome-nickel, stainless steel slats, work hardened for high resistance, with shiny surface having a roughness of $Ra < 0.3$ microns.
- Chrome-nickel, austenitic stainless steel pins and guide shoes (18% Chrome - 8% Nickel), work hardened for high resistance.

Model	L=Slat width		Code	Chain ref.	R=Minimum sideflexing radius	Weight
	mm	"				per metre
Flex RXMS 8°	82,6	3 1/4	S.8.23.040	SSH 881 K325	457	2,90
Flex RXMS 8°	114,3	4 1/2	S.8.23.080	SSH 881 K450	610	3,60
Flex RXMS 8°	190,5	7 1/2	S.8.23.110	SSH 881 K750	610	5,30
Flex RXMS Tab	82,6	3 1/4	S.8.23.041	SSH 881 T K325	457	3,10
Flex RXMS Tab	114,3	4 1/2	S.8.23.081	SSH 881 T K450	610	3,80
Flex RXMS Tab	190,5	7 1/2	S.8.23.111	SSH 881 T K750	610	5,50

Flex RXM

Inox 18/8

- Chrome-nickel, austenitic AISI 304 stainless steel slats (18% Chrome - 8% Nickel), work hardened for high resistance - shiny with a roughness of $Ra < 0.5$ microns.
- Chrome-nickel, austenitic stainless steel pins and guide shoes (18% Chrome - 8% Nickel), work hardened for high resistance.

Model	L=Slat width		Code	Chain ref.	R=Minimum	Weight
	mm	"			sideflexing radius	per metre
Flex RXM 8°	82,6	3 1/4	8.13.040	SSA 881 K325	457	2,90
Flex RXM 8°	114,3	4 1/2	8.13.080	SSA 881 K450	610	3,60
Flex RXM 8°	190,5	7 1/2	8.13.110	SSA 881 K750	610	5,30
Flex RXM Tab	82,6	3 1/4	8.13.041	SSA 881 T K325	457	3,10
Flex RXM Tab	114,3	4 1/2	8.13.081	SSA 881 T K450	610	3,80
Flex RXM Tab	190,5	7 1/2	8.13.111	SSA 881 T K750	610	5,50

Flex RXM 316

Inox 316

- Chrome-nickel, austenitic AISI 316L stainless steel slats (18% Chrome - 14% Nickel - 3% Molybdenum).
- Chrome-nickel, austenitic AISI 316 stainless steel pins and guide shoes.

Model	L=Slat width		Code	Chain ref.	R=Minimum sideflexing radius	Weight per metre
	mm	"			mm	Kg/m
Flex RXM 316 Tab	82,6	3 1/4	8.33.041*	SSAA 881 T K325	457	3,10
Flex RXM 316 Tab	114,3	4 1/2	8.33.081*	SSAA 881 T K450	610	3,80
Flex RXM 316 Tab	190,5	7 1/2	8.33.111*	SSAA 881 T K750	610	5,50

* Sizes produced only upon request. Delivery conditions and terms to be agreed.



Flex RXMA

Carbon Steel

- Heat-treated carbon steel slats, with a surface and core hardness of 43 HRC.
- Case hardened carbon steel pins.

Model	L=Slat width		Code	Chain ref.	R=Minimum sideflexing radius	Weight per metre
	mm	"			mm	Kg/m
Flex RXMA 8°	82,6	3 1/4	8.93.040	S 881 K325	457	2,90
Flex RXMA 8°	114,3	4 1/2	8.93.080	S 881 K450	610	3,60
Flex RXMA 8°	190,5	7 1/2	8.93.110	S 881 K750	610	5,30
Flex RXMA Tab	63,5	2 1/2	8.93.021	S 881 T K250	457	2,65
Flex RXMA Tab	82,6	3 1/4	8.93.041	S 881 T K325	457	3,10
Flex RXMA Tab	114,3	4 1/2	8.93.081	S 881 T K450	610	3,80
Flex RXMA Tab	190,5	7 1/2	8.93.111	S 881 T K750	610	5,50

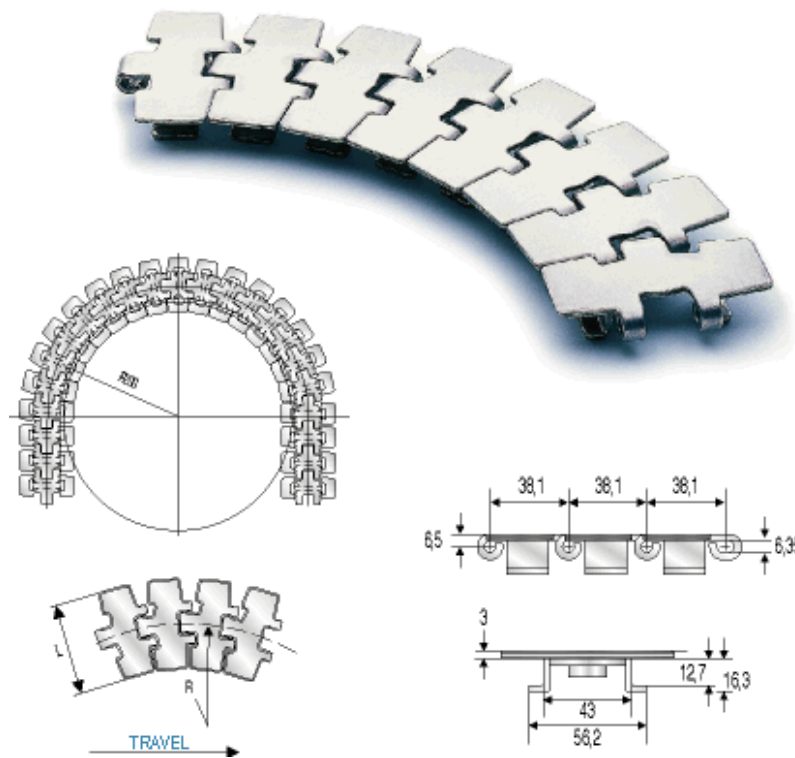

Flex FMS2

R = 200 mm

Hard Inox

- Special, chrome-nickel, stainless steel slats, work hardened for high resistance, with shiny surface having a roughness of $R_a < 0.3$ microns.
- Chrome-nickel, austenitic stainless steel pins and guide shoes (18% Chrome - 8% Nickel), work hardened for high resistance.

Model	L=Slat width		Code	Chain ref.	R=Minimum sideflexing radius	Weight per metre
	mm	"			mm	Kg/m
Flex FMS2 Tab	82,6	1 1/4	S.8.29.041	SSH 881 R T K325	200	3,00

Flex FM2

R = 200 mm

Inox 18/8

- Chrome-nickel, austenitic AISI 304 stainless steel slats (18% Chrome - 8% Nickel), work hardened for high resistance - shiny - with a roughness of $R_a < 0.5$ microns.
- Chrome-nickel, austenitic stainless steel pins and guide shoes (18% Chrome - 8% Nickel), work hardened for high resistance.

Model	L=Slat width		Code	Chain ref.	R=Minimum sideflexing radius	Weight per metre
	mm	"			mm	Kg/m
Flex FM2 Tab	82,6	3 1/4	8.19.041	SSA 881 R T K325	200	3,00

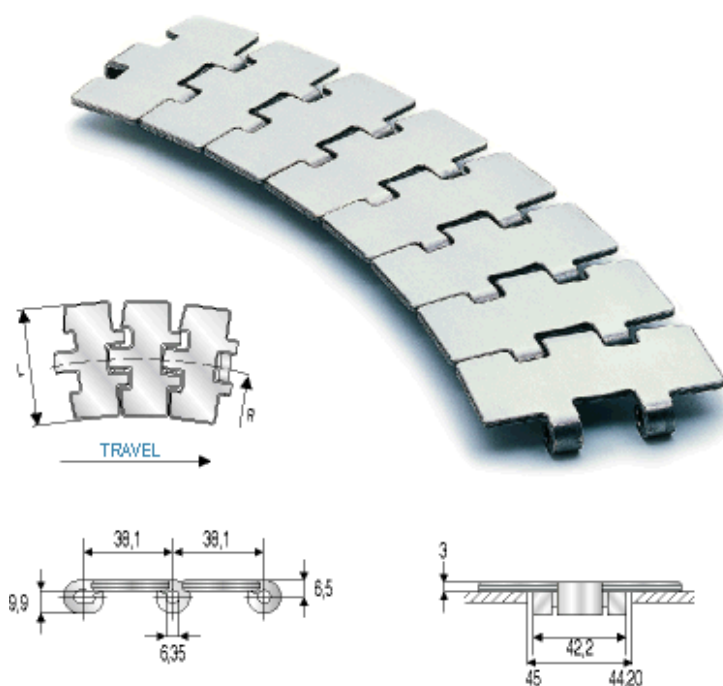

New Flex Mag

Hard Inox

- Special, chrome-nickel, stainless steel slats, work hardened for high resistance, with shiny surface having a roughness of Ra <0.3 microns.
- Special, stainless steel pins, 400 series - magnetic - work hardened for high resistance.

Model	L=Slat width		Code	Chain ref.	R=Minimum sideflexing radius	Weight per metre
	mm	"			mm	Kg/m
New Flex Mag	82,6	3 1/4	S.7.08.040	SSH 881 M K325	457	2,50
New Flex Mag	114,3	4 1/2	S.7.08.080	SSH 881 M K450	500	3,20
New Flex Mag	190,5	7 1/2	S.7.08.110	SSH 881 M K750	500	4,90

New Flex Mag-D

HQ Inox

- Special, new stainless steel, chrome - nickel (W.1.4589) slats - magnetic - work hardened for high resistance, with shiny surface having a

roughness of Ra < 0.2 microns.

- Special, stainless steel pins, 400 series - magnetic - work hardened for high resistance.

Model	L=Slat width		Code	Chain ref.	R=Minimum sideflexing radius	Weight per metre
	mm	"			mm	Kg/m
New Flex Mag-D	82,6	3 1/4	D.7.08.040*	SSX 881 M K325	457	2,50

* Sizes produced only upon request. Delivery conditions and terms to be agreed.

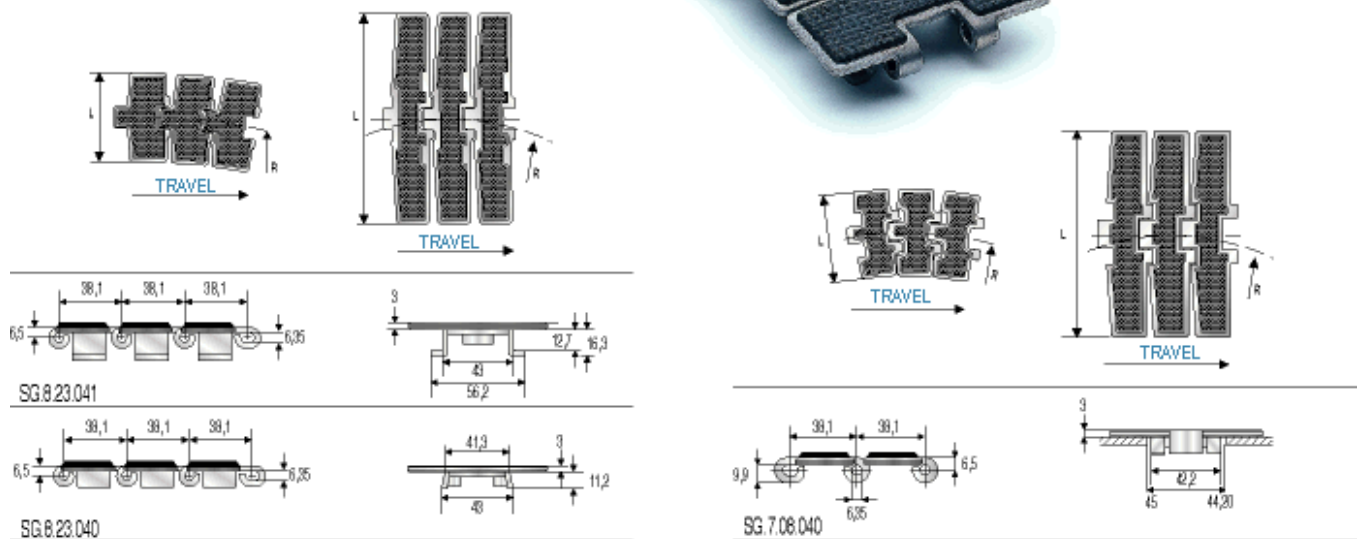

Flex RXMS-G

New Flex-G Mag
Hard Inox

- Special, chrome-nickel, stainless steel slats, work hardened for high resistance, with a rubber insert.
- Chrome-nickel, austenitic stainless steel pins and guide shoes (18% Chrome - 8% Nickel), work hardened for high resistance (Flex RXMS-G versions).
- Special, stainless steel pins, 400 series - magnetic - work hardened for high resistance (New Flex-G Mag versions).

Model	L=Slat width		Code	Chain ref.	R=Minimum sideflexing radius	Weight per metre
	mm	"			mm	Kg/m
Flex RXMS-G 8°	82,6	3 1/4	SG.8.23.040	SSH 881 G K325	457	3,10
Flex RXMS-G 8°	114,3	4 1/2	SG.8.23.080	SSH 881 G K450	610	3,80

Flex RXMS-G 8°	190,5	7 1/2	SG.8.23.110	SSH 881 G K750	610	5,50
Flex RXMS-G Tab	82,6	3 1/4	SG.8.23.041	SSH 881 T G K325	457	3,30
Flex RXMS-G Tab	114,3	4 1/2	SG.8.23.081	SSH 881 T G K450	610	4,00
Flex RXMS-G Tab	190,5	7 1/2	SG.8.23.111	SSH 881 T G K750	610	5,70
New Flex-G Mag	82,6	3 1/4	SG.7.08.040*	SSH 881 M G K325	457	2,70
New Flex-G Mag	190,5	7 1/2	SG.7.08.110*	SSH 881 M G K750	500	5,10

* Sizes produced only upon request. Delivery conditions and terms to be agreed.

[zurück zur Übersicht](#)

- [Flex FMS](#) - [Flex FMD](#) - [Flex FM](#) -

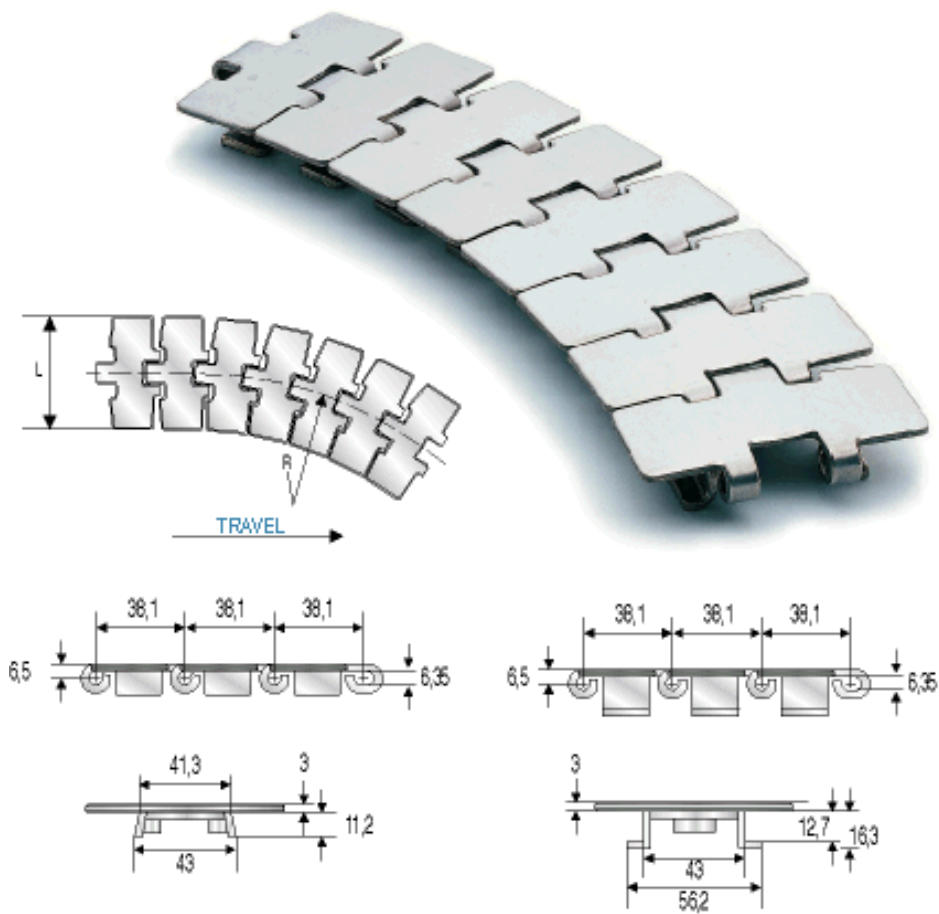

Flex FMS

Hard Inox

- Special, chrome-nickel, stainless steel slats, work hardened for high resistance, with shiny surface having a roughness of $R_a < 0.3$ microns.
- Chrome-nickel, austenitic stainless steel pins and guide shoes (18% Chrome - 8% Nickel), work hardened for high resistance.

Model	L=Slat width		Code	Chain ref.	R=Minimum sideflexing radius	Weight per metre
	mm	"			mm	Kg/m
Flex FMS 8°	82,6	3 1/4	S.8.26.040	SSH 8811 K325	457	2,90
Flex FMS 8°	88,9	3 1/2	S.8.26.060	SSH 8811 K350	500	3,10
Flex FMS Tab	82,6	3 1/4	S.8.26.041	SSH 8811 T K325	457	3,10
Flex FMS Tab	88,9	3 1/2	S.8.26.061	SSH 8811 T K350	500	3,30

Flex FMD

HQ Inox

- Special, new stainless steel, chrome-nickel (W.1.4589) slats, work hardened for high resistance, with low surface roughness, $R_a < 0.2$ microns.
- Special, stainless steel pins, 400 series - magnetic - work hardened for high resistance.

Model	L=Slat width		Code	Chain ref.	R=Minimum sideflexing radius	Weight per metre
	mm	"			mm	Kg/m
Flex FMD Tab	82,6	3 1/4	D.8.26.041	SSX 8811 T K 325	457	3,10

Flex FM

Inox 18/8

- Chrome-nickel, austenitic AISI 304 stainless steel slats (18% Chrome - 8% Nickel), work hardened for high resistance - shiny - with a roughness of $R_a < 0.5$ microns.
- Chrome-nickel, austenitic stainless steel pins and guide shoes (18% Chrome - 8% Nickel), work hardened for high resistance.

Model	L=Slat width		Code	Chain ref.	R=Minimum sideflexing radius	Weight per metre
	mm	"			mm	Kg/m

Flex FM 8°	82,6	3 1/4	8.16.040	SSA 8811 K325	457	2,90
Flex FM 8°	88,9	3 1/2	8.16.060	SSA 8811 K350	500	3,10
Flex FM Tab	82,6	3 1/4	8.16.041	SSA 8811 T K325	457	3,10
Flex FM Tab	88,9	3 1/2	8.16.061	SSA 8811 T K350	500	3,30

[zurück zur Übersicht](#)

- 1864 -

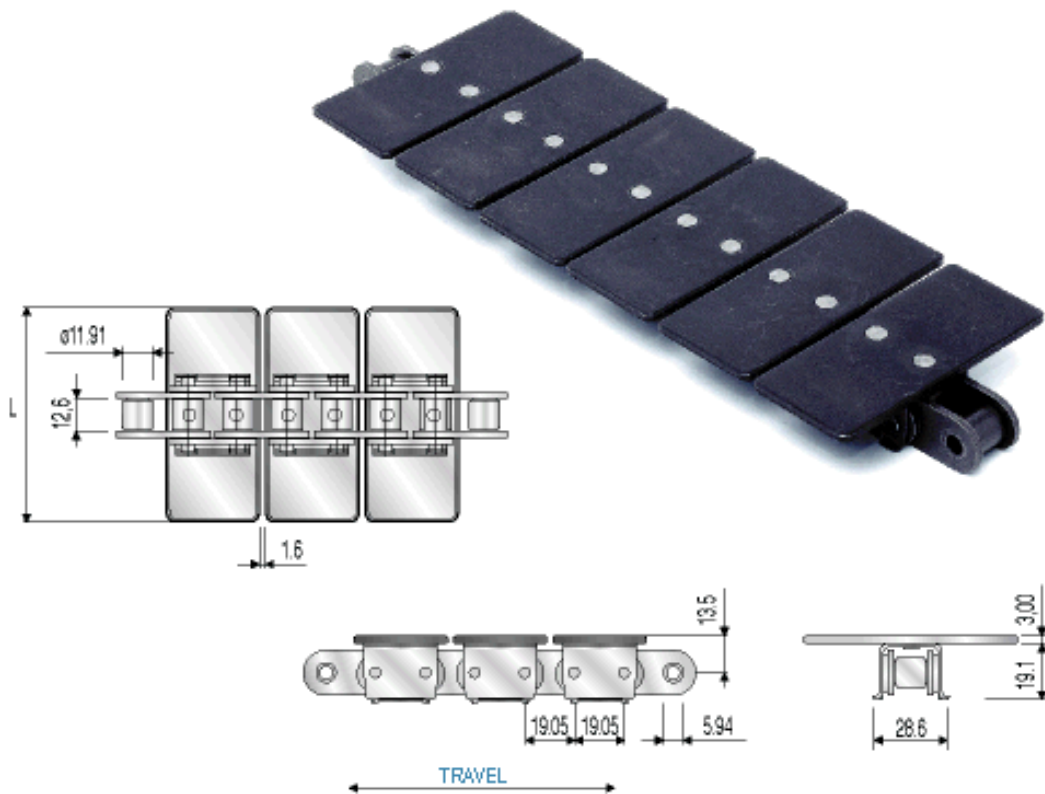

1864

- This high speed, high capacity series offers better efficiency and reliability in applications where high temperatures or abrasive materials are involved.
- Straight running: steel and stainless steel top plates, 19,05 mm - 3/4" pitch.

Code	Chain ref.	Ultimate strength	Base chain material	Top plate material	L= Slat width	Weight per metre
		N			mm	Kg/m
1864.CC.041	1864 K325	37000	Steel	Steel	82,6	3,33
1864.CC.081	1864 K450				114,3	4,00

1864.CC.101	1864 K600				152,4	5,33
1864.CC.111	1864 K750				190,5	5,68
1864.CS.041	1864 A K325	37000	Steel	Stainless Steel	82,6	3,33
1864.CS.081	1864 A K450				114,3	4,00
1864.CS.101	1864 A K600				152,4	5,33
1864.CS.111	1864 A K750				190,5	5,68
1864.SS.041	1864 SS K325	26000	Stainless Steel	Stainless Steel	82,6	3,33
1864.SS.081	1864 SS K450				114,3	4,00
1864.SS.101	1864 SS K600				152,4	5,33
1864.SS.111	1864 SS K750				190,5	5,68

[zurück zur Übersicht](#)

- Standard - Super - Accate -
- Super-DHG -

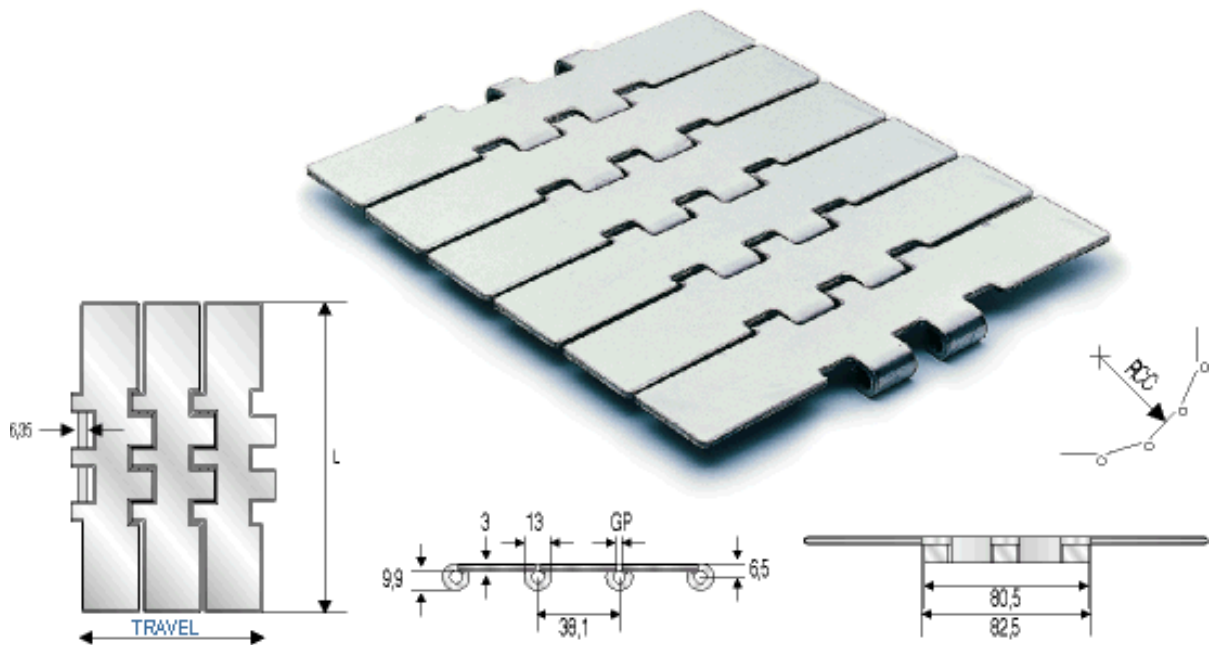

Standard

Inox

- Ferritic, AISI 430 stainless steel slats, work hardened, with shiny surface having low roughness.
- Chrome-nickel, austenitic stainless steel pins (18% Chrome - 8% Nickel), work hardened for high resistance.

Model	L=Slat width		Code	Chain ref.	Hardness	GP	RCC	Weight per metre
	mm	"						
Standard	190,5	7 1/2	7.04.110	SS 802 K750	20	1,8	150	5,80

Super

Hard Inox

- Special, chrome-nickel, stainless steel slats, work hardened for high resistance, with shiny surface having a roughness of Ra < 0.3 microns.
- Chrome-nickel, austenitic stainless steel pins (18% Chrome - 8% Nickel), work hardened for high resistance.

Model	L=Slat width		Code	Chain ref.	Hardness	GP	RCC	Weight per metre
	mm	"						
Super	190,5	7 1/2	S.7.04.110	SSH 802 K750	30	1,8	150	5,80



Accate

Carbon Steel

- Heat-treated carbon steel slats, with a surface and core hardness of 43 HRC.
- Case hardened carbon steel pins.

Model	L=Slat width		Code	Chain ref.	Hardness	GP	RCC	Weight per metre
	mm	"						
Accate	190,5	7 1/2	7.94.110	S 802 K750	43	1,8	150	5,80

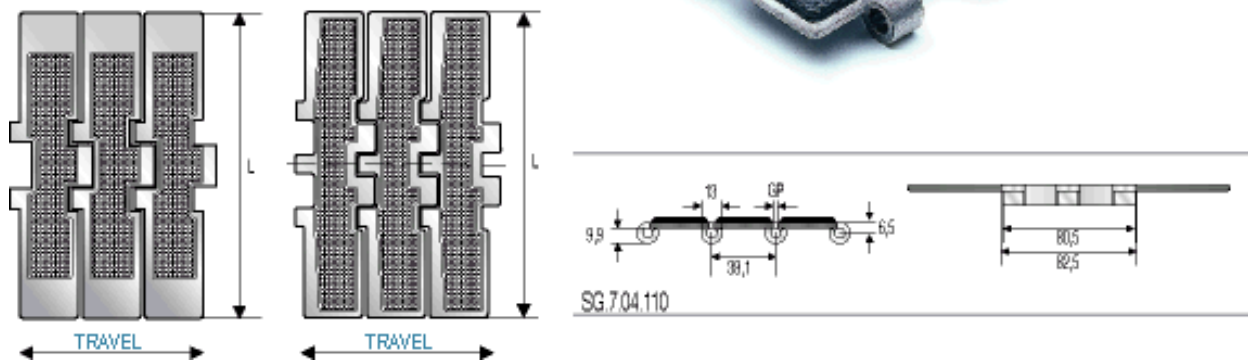
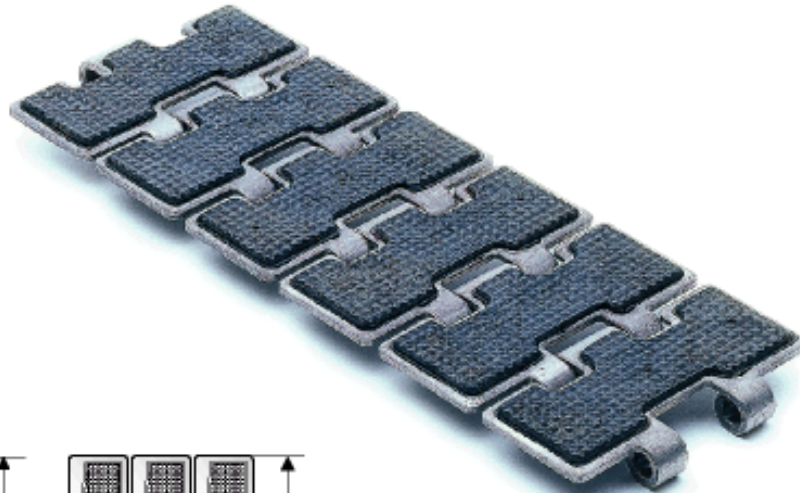

Super-DHG

Hard Inox

- Special, chrome-nickel, stainless steel slats, work hardened for high resistance, with a rubber insert.
- Chrome-nickel, austenitic stainless steel pins and guide shoes (18% Chrome - 8% Nickel), work hardened for high resistance.

Model	L=Slat width		Code	Chain ref.	Hardness	GP	RCC	Weight per metre
	mm	"						
Super-DHG	190,5	7 1/2	SG.7.04.110	SSH 802 G K750	30	1,8	150	6,20

[zurück zur Übersicht](#)

- Stella D. -

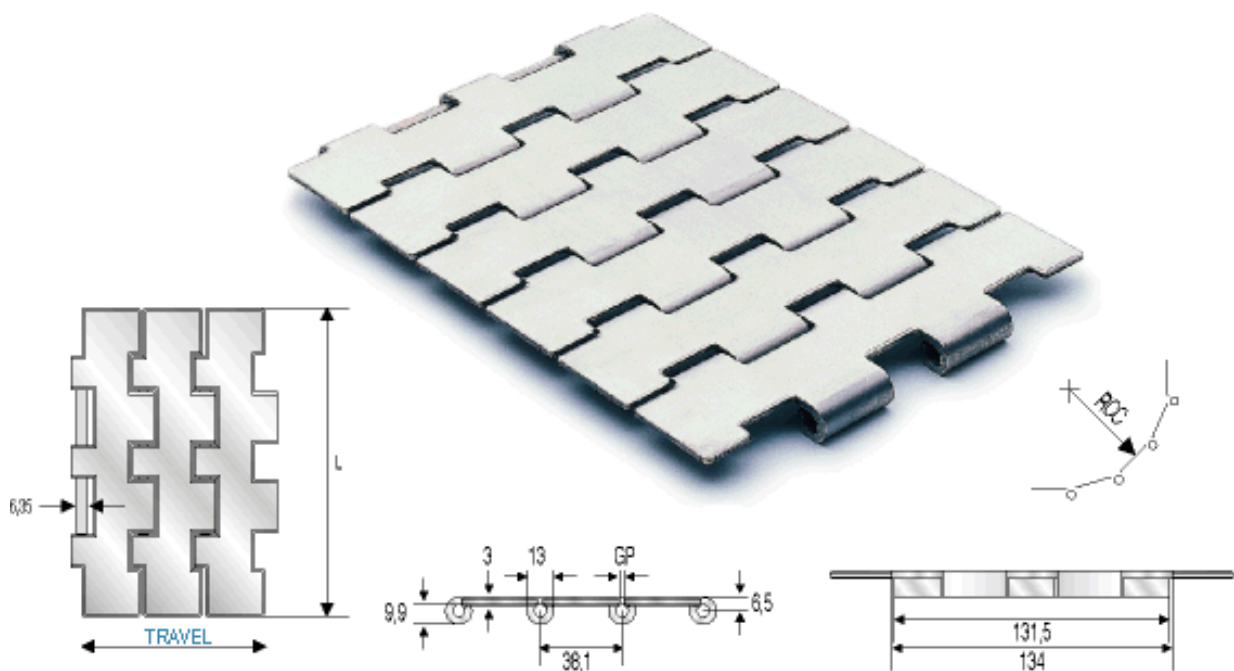

Stella D.

Inox 18/8

- Chrome-nickel, austenitic AISI 304 stainless steel slats (18% Chrome - 8% Nickel), work hardened for high resistance - shiny - with a roughness of $R_a < 0.5$ microns.
- Chrome-nickel, austenitic stainless steel pins (18% Chrome - 8% Nickel), work hardened for high resistance.

Model	L=Slat width		Code	Chain ref.	Hardness	GP	RCC	Weight per metre
	mm	"						
Stella D.	170,0	-	7.24.050	SSA 804 K670	26	2,5	90	6,30
Stella D.	190,5	7 1/2	7.24.060	SSA 804 K750	26	2,5	90	6,80

- Stella D. -

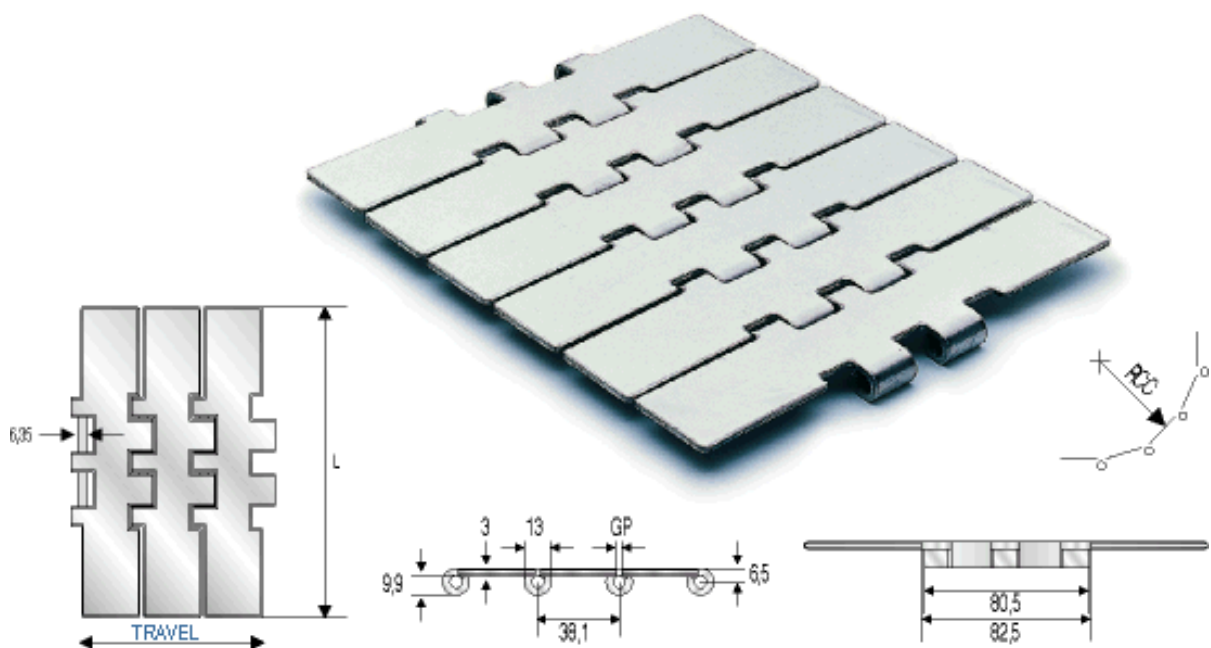

Stella D.

Inox 18/8

- Chrome-nickel, austenitic AISI 304 stainless steel slats (18% Chrome - 8% Nickel), work hardened for high resistance - shiny - with a roughness of Ra < 0.5 microns.
- Chrome-nickel, austenitic stainless steel pins (18% Chrome - 8% Nickel), work hardened for high resistance.

Model	L=Slat width		Code	Chain ref.	Hardness	GP	RCC	Weight per metre
	mm	"						
Stella D.	190,5	7 1/2	7.14.110	SSA 805 K750	26	1,8	150	5,80

- Super - Superspeed - Wear-proof - Standard - Special -
 - Standard Mignon - Super Mignon - Super-G -

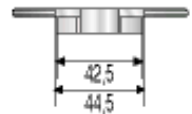
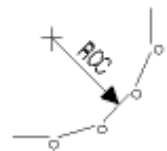
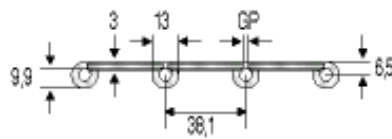
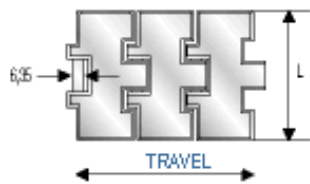
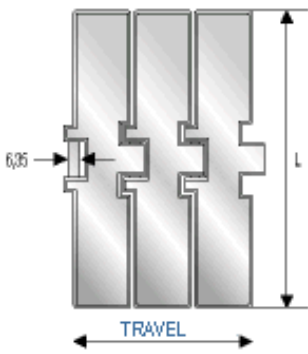
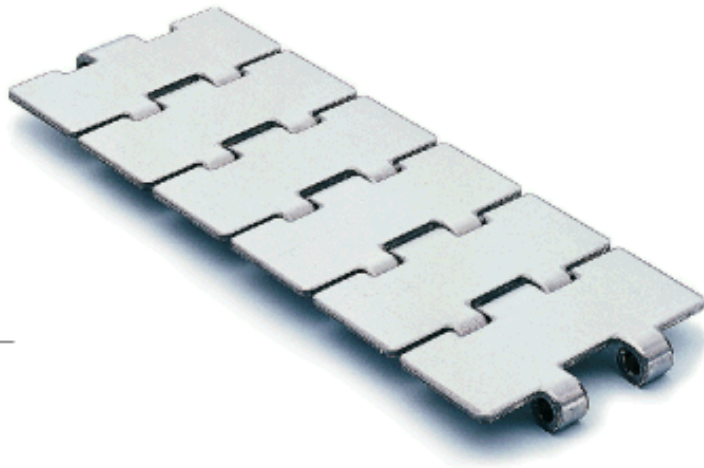

Super

Hard Inox

- Special, chrome-nickel, stainless steel slats, work hardened for high resistance, with shiny surface having a roughness of Ra < 0.3 microns.
- Chrome-nickel, austenitic stainless steel pins (18% Chrome - 8% Nickel), work hardened for high resistance.

Model	L=Slat width		Code	Chain ref.	Hardness	GP	RCC	Weight per metre
	mm	"						
Super	54,1	-	S.7.00.013*	SSHR 812 K213	30	2,8	80	2,10

Super	63,5	2 1/2	S.7.00.020	SSHR 812 K250	30	2,8	80	2,20
Super	66,7	2 5/8	S.7.00.025	SSHR 812 K263	30	2,8	80	2,30
Super	76,2	3	S.7.00.030	SSHR 812 K300	30	2,8	80	2,45
Super	82,6	3 1/4	S.7.00.040	SSHR 812 K325	30	2,8	80	2,60
Super	85,0	-	S.7.00.050*	SSHR 812 K335	30	2,8	80	2,68
Super	88,9	3 1/2	S.7.00.060	SSHR 812 K350	30	2,8	80	2,70
Super	127,0	5	S.7.00.090	SSHR 812 K500	30	2,8	80	3,50

Super	57,1	2 1/4	S.7.00.015*	SSH 812 K225	30	1,8	150	2,18
Super	63,5	2 1/2	S.7.00.021	SSH 812 K250	30	1,8	150	2,25
Super	69,9	2 3/4	S.7.00.200	SSH 812 K275	30	1,8	150	2,35
Super	76,2	3	S.7.00.031	SSH 812 K300	30	1,8	150	2,50
Super	82,6	3 1/4	S.7.00.041	SSH 812 K325	30	1,8	150	2,65
Super	95,3	3 3/4	S.7.00.065*	SSH 812 K375	30	1,8	150	2,85
Super	101,6	4	S.7.00.070	SSH 812 K400	30	1,8	150	3,00
Super	114,3	4 1/2	S.7.00.080	SSH 812 K450	30	1,8	150	3,30
Super	152,4	6	S.7.00.100	SSH 812 K600	30	1,8	150	4,20
Super	190,5	7 1/2	S.7.00.110	SSH 812 K750	30	1,8	150	5,10

* Sizes produced only upon request. Delivery conditions and terms to be agreed.

Superspeed

HQ Inox

- Special, new stainless steel, chrome-nickel (W.1.4589) slats, work hardened for high resistance with very little roughness, Ra < 0.18 microns.
- Special, stainless steel pins, 400 series - magnetic - work hardened for high resistance.

The chain is produced with a special profile and perfect levelness, a quality which, together with the shiny surface, makes it particularly suitable for pressureless combiners/inliners and for high speed systems.

Model	L=Slat width		Code	Chain ref.	Hardness	GP	RCC	Weight per metre
	mm	"						
Superspeed	82,6	3 1/4	DX.7.00.040	SSX 812 K325	30	1,6	80	2,60

Wear-proof

HQ Inox

- Special, new stainless steel, chrome-nickel (W.1.4589) slats, work hardened for high resistance with very little surface roughness, Ra < 0.2 microns.
- Special, stainless steel pins, 400 series - magnetic - work hardened for high resistance.

Model	L=Slat width		Code	Chain ref.	Hardness	GP	RCC	Weight per metre
	mm	"			HRC	mm	mm	Kg/m
Wear-Proof	82,6	3 1/4	D.7.00.040	SSHQR 812 K325	30	2,8	80	2,60
Wear-Proof	82,6	3 1/4	D.7.00.041	SSHQ 812 K325	30	1,8	150	2,65

Standard

Inox

- Ferritic, AISI 430 stainless steel slats, work hardened, with shiny surface having low roughness.
- Chrome-nickel, austenitic stainless steel pins (18% Chrome - 8% Nickel), work hardened for high resistance.

Model	L=Slat width		Code	Chain ref.	Hardness	GP	RCC	Weight per metre
	mm	"			HRC	mm	mm	Kg/m
Standard	54,1	-	7.00.013*	SSR 812 K213	20	2,8	80	2,10
Standard	63,5	2 1/2	7.00.020	SSR 812 K250	20	2,8	80	2,20
Standard	66,7	2 5/8	7.00.025	SSR 812 K263	20	2,8	80	2,30
Standard	76,2	3	7.00.030	SSR 812 K300	20	2,8	80	2,45
Standard	85,0	-	7.00.050*	SSR 812 K335	20	2,8	80	2,68
Standard	88,9	3 1/2	7.00.060	SSR 812 K350	20	2,8	80	2,70
Standard	57,1	2 1/4	7.00.015*	SS 812 K225	20	1,8	150	2,18
Standard	63,5	2 1/2	7.00.021	SS 812 K250	20	1,8	150	2,25
Standard	69,9	2 3/4	7.00.200*	SS 812 K275	20	1,8	150	2,35
Standard	76,2	3	7.00.031	SS 812 K300	20	1,8	150	2,50
Standard	82,6	3 1/4	7.00.041	SS 812 K325	20	1,8	150	2,65
Standard	101,6	4	7.00.070	SS 812 K400	20	1,8	150	3,00
Standard	114,3	4 1/2	7.00.080	SS 812 K450	20	1,8	150	3,30
Standard	152,4	6	7.00.100	SS 812 K600	20	1,8	150	4,20
Standard	190,5	7 1/2	7.00.110	SS 812 K750	20	1,8	150	5,10

* Sizes produced only upon request. Delivery conditions and terms to be agreed.

Special

Inox

- Ferritic, AISI 430 stainless steel slats, work hardened, with shiny surface having low roughness.
- Chrome-nickel, austenitic stainless steel pins (18% Chrome - 8% Nickel), work hardened for high resistance

Model	L=Slat width		Code	Chain ref.	Hardness	GP	RCC	Weight per metre
	mm	"			HRC	mm	mm	Kg/m
Special	82,6	3 1/4	H.7.00.040	SSR 812 K325	20	2,8	80	2,55

MIGNON

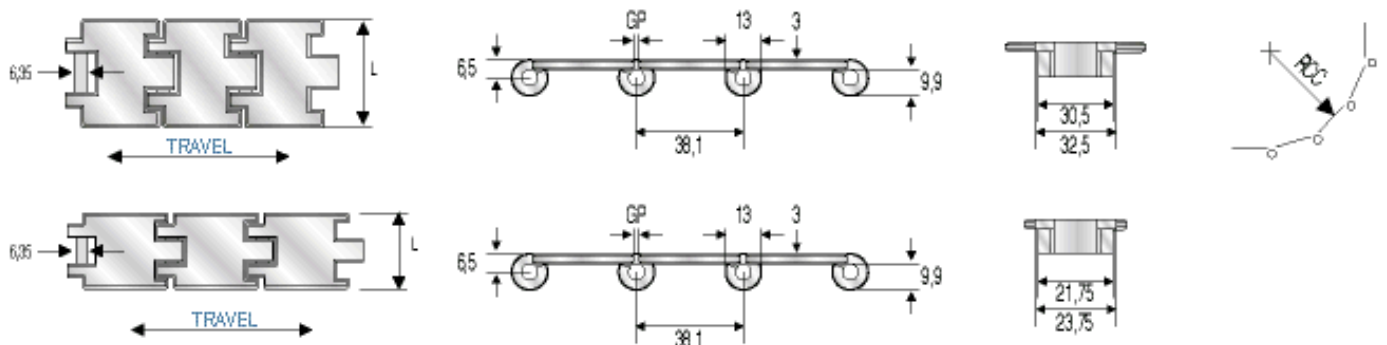
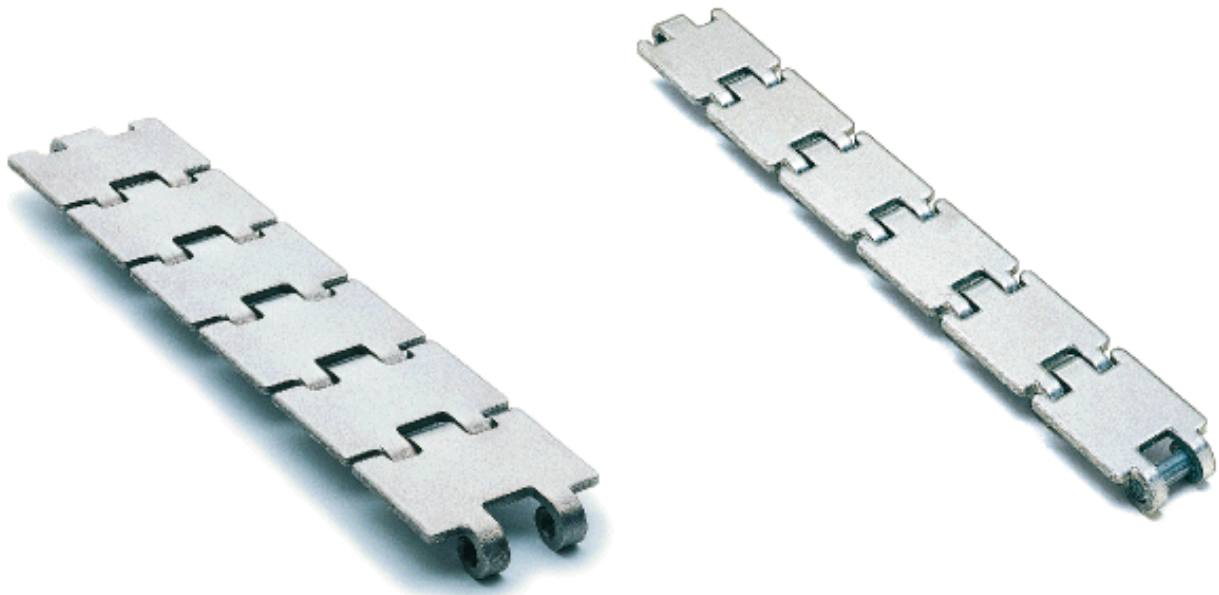

Standard

Inox

- Ferritic, AISI 430 stainless steel slats, work hardened, with shiny surface having low roughness.
- Chrome-nickel, austenitic stainless steel pins (18% Chrome - 8% Nickel), work hardened for high resistance.

Model	L=Slat width		Code	Chain ref.	Hardness	GP	RCC	Weight per metre
	mm	"						
Standard	50,0	-	7.00.010	SSR 812 K197	20	2,5	90	1,60

Super

Hard Inox

- Special, chrome-nickel, stainless steel, slats, work hardened for high resistance, with shiny surface having a roughness of Ra < 0.3 microns.
- Special, stainless steel pins, 400 series - magnetic - work hardened for high resistance.

Model	L=Slat width		Code	Chain ref.	Hardness	GP	RCC	Weight per metre
	mm	"				mm	mm	Kg/m
Super	31,8	1 1/4	8.25.280	SSHR 812 K125	30	2,8	75	1,10
Super	44,5	1 3/4	8.25.300	SSHR 812 K175	30	2,8	75	1,30

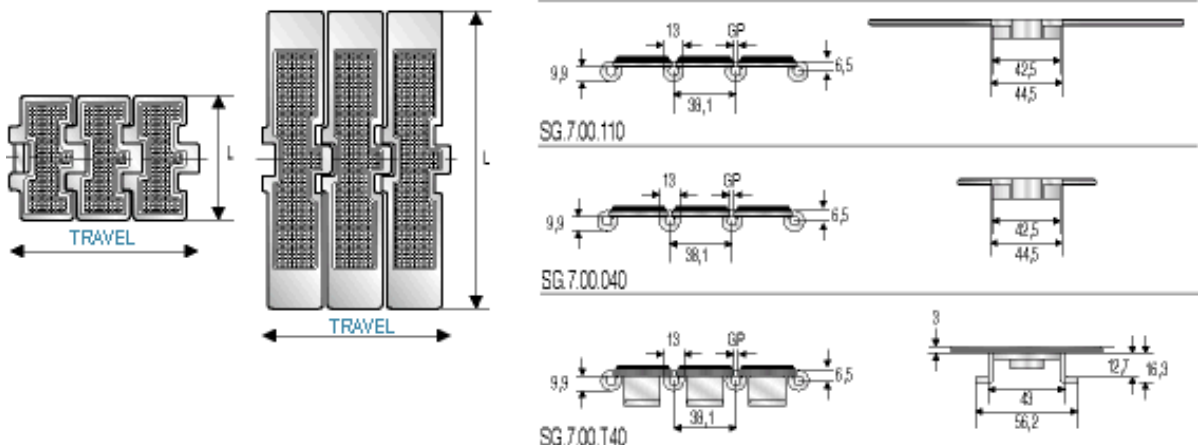
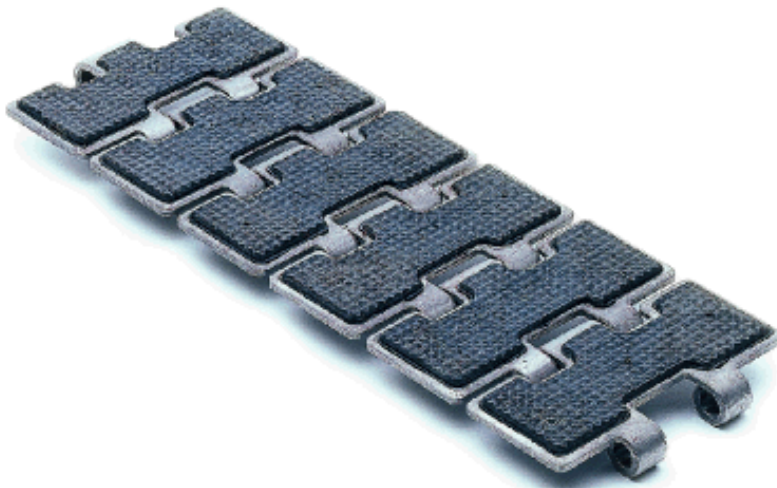

Super-G

Hard Inox

- Special, chrome-nickel, stainless steel slats, work hardened for high resistance, with a rubber insert.
- Chrome-nickel, austenitic stainless steel pins and guide shoes (18% Chrome -8% Nickel), work hardened for high resistance.

Model	L=Slat width		Code	Chain ref.	Hardness	GP	RCC	Weight per metre
	mm	"			HRC	mm	mm	Kg/m
Super-G	82,6	3 1/4	SG.7.00.040	SSHR 812 G K325	30	2,8	80	2,80
Super-G Tab	82,6	3 1/4	SG.7.00. T40	SSHR 812 T G K325	30	2,8	80	3,40
Super-G	114,3	4 1/2	SG.7.00.080	SSH 812 G K450	30	1,8	150	3,50
Super-G	152,4	6	SG.7.00.100	SSH 812 G K600	30	1,8	150	4,40
Super-G	190,5	7 1/2	SG.7.00.110	SSH 812 G K750	30	1,8	150	5,30

[zurück zur Übersicht](#)

- Super - Super-G -

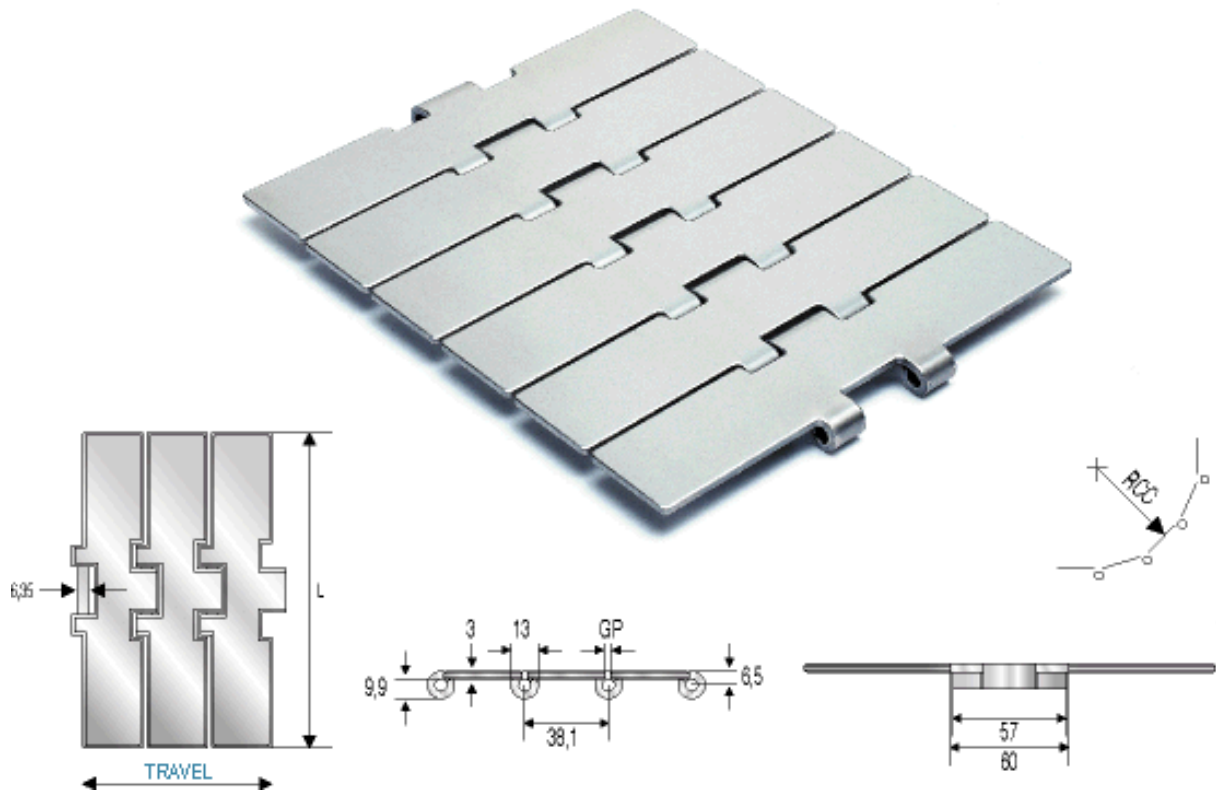

Super

Hard Inox

- Special, chrome-nickel, stainless steel, slats, work hardened for high resistance, with shiny surface having a roughness of $Ra < 0.3$ microns.
- Chrome-nickel, austenitic stainless steel pins (18% Chrome - 8% Nickel), work hardened for high resistance.

Model	L=Slat width		Code	Chain ref.	Hardness	GP	RCC	Weight per metre
	mm	"						
Super	190,5	7 1/2	S.7.00.175	SSH 8127 K750	30	1,6	150	5,10

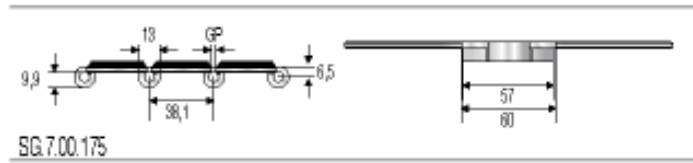
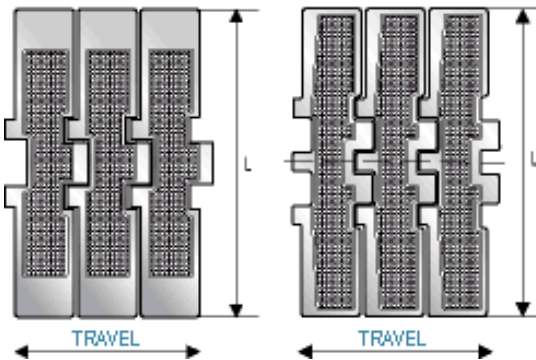
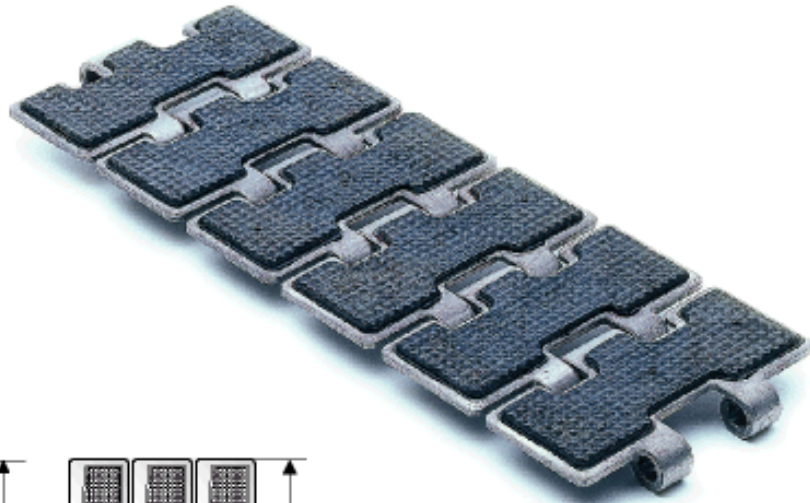

Super-G

Hard Inox

- Special, chrome-nickel, stainless steel slats, work hardened for high resistance, with a rubber insert.
- Chrome-nickel, austenitic stainless steel pins and guide shoes (18% Chrome - 8% Nickel), work hardened for high resistance.

Model	L=Slat width		Code	Chain ref.	Hardness	GP	RCC	Weight per metre
	mm	"						
Super-G	190,5	7 1/2	SG.7.00.175	SSH 8127 G K750	30	1,6	150	5,35

- Stella D. - 316 - Accate - Accate-C -
- Stella D. Mignon -

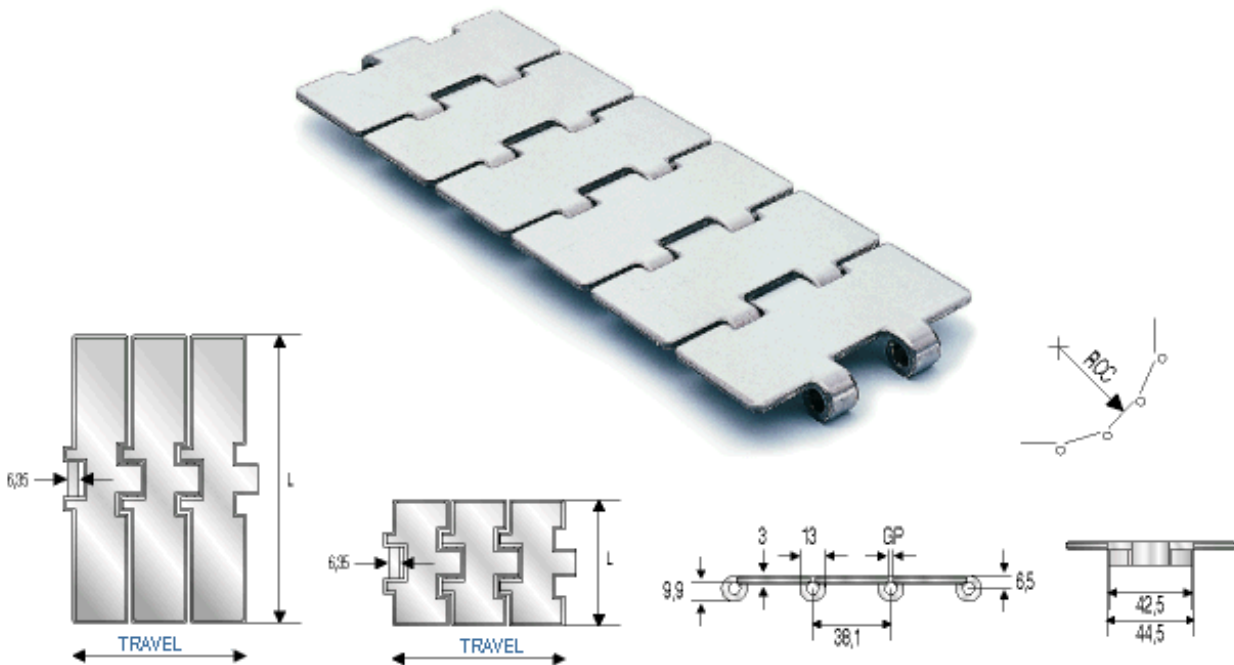

Stella D.

Inox 18/8

- Chrome-nickel, austenitic AISI 304 stainless steel slats (18% Chrome - 8% Nickel), work hardened for high resistance - shiny - with a roughness of Ra < 0.5 microns.
- Chrome-nickel, austenitic stainless steel pins (18% Chrome - 8% Nickel), work hardened for high resistance.

Model	L=Slat width		Code	Chain ref.	Hardness	GP	RCC	Weight per metre
	mm	"						
Stella D.	54,1	-	7.10.013*	SSAR 815 K213	26	2,8	80	2,10
Stella D.	63,5	2 1/2	7.10.020	SSAR 815 K250	26	2,8	80	2,20

Stella D.	66,7	2 5/8	7.10.025	SSAR 815 K263	26	2,8	80	2,30
Stella D.	76,2	3	7.10.030	SSAR 815 K300	26	2,8	80	2,45
Stella D.	82,6	3 1/4	7.10.040	SSAR 815 K325	26	2,8	80	2,60
Stella D.	85,0	-	7.10.050*	SSAR 815 K335	26	2,8	80	2,68
Stella D.	88,9	3 1/2	7.10.060	SSAR 815 K350	26	2,8	80	2,70
Stella D.	127,0	5	7.10.090	SSAR 815 K500	26	2,8	80	3,50

Stella D.	57,1	2 1/4	7.10.015*	SSA 815 K225	26	1,8	150	2,18
Stella D.	63,5	2 1/2	7.10.021	SSA 815 K250	26	1,8	150	2,25
Stella D.	69,9	2 3/4	7.10.200	SSA 815 K275	26	1,8	150	2,35
Stella D.	76,2	3	7.10.031	SSA 815 K300	26	1,8	150	2,50
Stella D.	82,6	3 1/4	7.10.041	SSA 815 K325	26	1,8	150	2,65
Stella D.	95,3	3 3/4	7.10.065*	SSA 815 K375	26	1,8	150	2,85
Stella D.	101,6	4	7.10.070	SSA 815 K400	26	1,8	150	3,00
Stella D.	114,3	4 1/2	7.10.080	SSA 815 K450	26	1,8	150	3,30
Stella D.	152,4	6	7.10.100	SSA 815 K600	26	1,8	150	4,20
Stella D.	190,5	7 1/2	7.10.110	SSA 815 K750	26	1,8	150	5,10

* Sizes produced only upon request. Delivery conditions and terms to be agreed.

316

Inox 316

- Chrome-nickel, austenitic AISI 316L stainless steel slats (18% Chrome - 14% Nickel -3% Molybdenum).
- Chrome-nickel, austenitic AISI 316 stainless steel pins.

Model	L=Slat width		Code	Chain ref.	Hardness	GP	RCC	Weight per metre
	mm	"						
316	82,6	3 1/4	7.25.041*	SSAA 815 K325	-	1,8	150	2,65
316	114,3	4 1/2	7.25.080*	SSAA 815 K450	-	1,8	150	3,30
316	152,4	6	7.25.100*	SSAA 815 K600	-	1,8	150	4,20
316	190,5	7 1/2	7.25.110*	SSAA 815 K750	-	1,8	150	5,10

* Sizes produced only upon request. Delivery conditions and terms to be agreed.

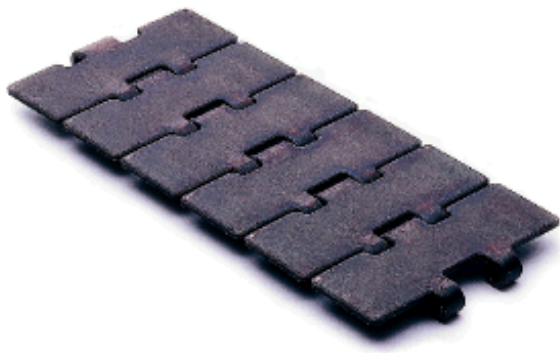

Accate

Carbon Steel

- Heat-treated carbon steel slats.
- Case hardened carbon steel pins.

Model	L=Slat width		Code	Chain ref.	Core Hardness	Surface Hardness	GP	RCC	Weight per metre
	mm	"							
Accate	63,5	2 1/2	7.90.020	SR 815 K250	43	43	2,8	80	2,20
Accate	66,7	2 5/8	7.90.025*	SR 815 K263	43	43	2,8	80	2,30
Accate	76,2	3	7.90.030	SR 815 K300	43	43	2,8	80	2,45
Accate	82,6	3 1/4	7.90.040	SR 815 K325	43	43	2,8	80	2,60
Accate	88,9	3 1/2	7.90.060	SR 815 K350	43	43	2,8	80	2,70
Accate	127,0	5	7.90.090	SR 815 K500	43	43	2,8	80	3,50
Accate	57,1	2 1/4	7.90.015	S 815 K225	43	43	1,8	150	2,15
Accate	63,5	2 1/2	7.90.021	S 815 K250	43	43	1,8	150	2,22
Accate	76,2	3	7.90.031	S 815 K300	43	43	1,8	150	2,50
Accate	82,6	3 1/4	7.90.041	S 815 K325	43	43	1,8	150	2,65
Accate	101,6	4	7.90.070	S 815 K400	43	43	1,8	150	3,00
Accate	114,3	4 1/2	7.90.080	S 815 K450	43	43	1,8	150	3,30
Accate	120,0	-	7.90.220*	S 815 K473	43	43	1,8	150	3,45
Accate	152,4	6	7.90.100	S 815 K600	43	43	1,8	150	4,20
Accate	190,5	7 1/2	7.90.110	S 815 K750	43	43	1,8	150	5,10

* Sizes produced only upon request. Delivery conditions and terms to be agreed.

Accate-C

Carbon Steel

- Case hardened carbon steel slats and pins.

Model	L=Slat width		Code	Chain ref.	Core Hardness	Surface Hardness	GP	RCC	Weight per metre
	mm	"							
Accate-C	82,6	3 1/4	C.7.90.040*	SCR 815 K325	40	55	2,8	80	2,60

Accate- C	82,6 3 1/4	C.7.90.041	SC 815 K325	40	55	1,8	150	2,65
Accate- C	114,3 4 1/2	C.7.90.080*	SC 815 K450	40	55	1,8	150	3,30

* Sizes produced only upon request. Delivery conditions and terms to be agreed.

MIGNON

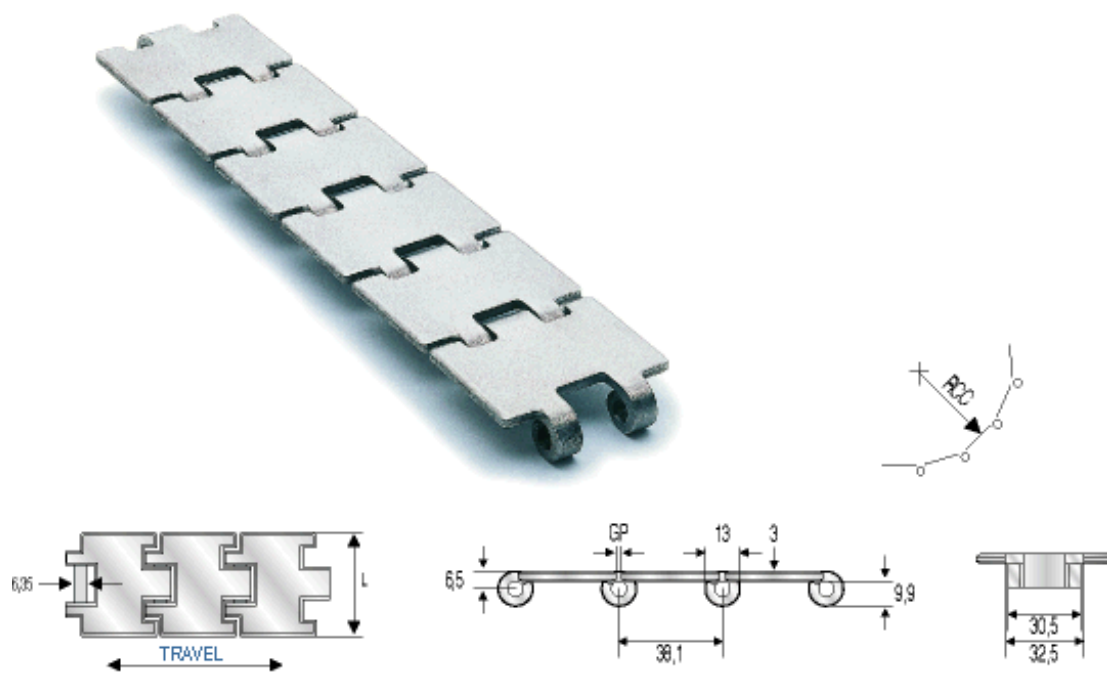

Stella D.

Inox 18/8

- Chrome-nickel, austenitic AISI 304 stainless steel slats (18% Chrome - 8% Nickel), work hardened for high resistance - shiny - with a roughness of Ra < 0.5 microns.
- Chrome-nickel, austenitic stainless steel pins (18% Chrome - 8% Nickel), work hardened for high resistance.

Model	L=Slat width		Code	Chain ref.	Hardness	GP	RCC	Weight per metre
	mm	"			HRC	mm	mm	Kg/m
Stella D.	50,0	-	7.10.010	SSAR 815 K197	26	2,5	90	1,60

[zurück zur Übersicht](#)